

MOTO GUZZI WOULD LIKE TO THANK YOU

for choosing one of its products. We have compiled this booklet to provide a comprehensive overview of your vehicle's quality features. Please read it carefully before riding the vehicle for the first time. It contains information, tips and precautions for using your vehicle. It also describes features, details and devices to assure you that you have made the right choice. We believe that if you follow our suggestions, you will soon get to know your new vehicle well and that it will continue to give you satisfactory service for many years to come. This booklet forms an integral part of the vehicle; should the vehicle be sold, it must be transferred to the new owner.

V100 Mandello - V100 Mandello S



The instructions in this manual have been prepared to offer mainly a simple and clear guide to its use; it also describes routine maintenance procedures and regular checks that should be carried out on the vehicle at an **authorised Moto Guzzi Dealer or Workshop**. The booklet also contains instructions for simple repairs. Any operations not specifically described in this booklet require the use of special tools and/or particular technical knowledge; for these operations, please take your vehicle to an **authorised Moto Guzzi Dealer or Workshop**.



Personal safety

Failure to completely observe these instructions will result in serious risk of personal injury.



Safeguarding the environment

Sections marked with this symbol indicate the correct use of the vehicle to prevent damaging the environment.



Vehicle intactness

The incomplete or non-observance of these regulations leads to the risk of serious damage to the vehicle and sometimes even the invalidity of the guarantee

The symbols illustrated above are very important. They are used to highlight parts of the booklet that should be read with particular care. The different symbols are used to make each topic in the manual simple and quick to locate. Before starting the engine, read this booklet thoroughly and the "SAFE RIDING" section in particular. Your safety as well as other's does not only depend on the quickness of your reflexes and agility, but also on how well you know your vehicle, the state of maintenance of the vehicle itself and your knowledge of the rules for SAFE RIDING. For your safety, get to know your vehicle well so as to safely ride and master it in road traffic IMPORTANT This booklet is an integral part of the vehicle, and must be handed to the new owner in the event of sale.

INDEX

GENERAL RULES	7	USB Port.....	101
Carbon monoxide.....	8	Identification.....	102
Fuel.....	8	Adjusting the windscreen.....	103
Hot components.....	9	USE	105
Warning lights.....	9	Checks.....	106
Coolant.....	10	Refuelling.....	108
Used engine oil and gearbox oil.....	11	Rear shock absorbers adjustment.....	111
Brake fluid.....	11	Rear shock absorbers setting.....	113
Battery hydrogen gas and electrolyte.....	12	Front fork adjustment.....	116
Precautions general advice.....	12	Front fork setting.....	119
VEHICLE	15	Adjusting the front brake lever.....	122
Arrangement of the main components.....	16	Rear brake pedal adjustment.....	122
Dashboard.....	19	Clutch lever adjustment.....	123
Digital instrument panel.....	20	Running in.....	123
Light unit.....	22	Starting up the engine.....	124
Digital lcd display.....	22	Moving off / riding.....	127
Alarms.....	28	Stopping the engine.....	131
Mapping selection.....	34	Parking.....	131
Control buttons.....	36	Catalytic silencer.....	132
Advanced functions.....	51	Stand.....	133
Ignition switch.....	86	Suggestion to prevent theft.....	134
Locking the steering wheel.....	87	Safe driving.....	135
Horn button.....	88	Basic safety rules.....	137
Switch direction indicators.....	89	MAINTENANCE	143
High/low beam selector.....	90	Foreword.....	144
Passing button.....	90	Engine oil level check.....	144
Daytime/night lights switch.....	91	Engine oil top-up.....	146
Heated handgrip control.....	92	Engine oil change.....	146
Start-up button.....	93	Engine oil filter replacement.....	146
Engine stop switch.....	94	Bevel gear pair oil level.....	147
Button Cruise Control.....	94	Tyres.....	147
Immobilizer system operation.....	97	Spark plug dismantlement.....	149
Opening the saddle.....	99	Removing the air filter.....	150

Cooling fluid level.....	150
Coolant check.....	151
Coolant top-up.....	151
Checking the brake oil level.....	152
Braking system fluid top up.....	153
Checking clutch fluid.....	153
Topping up clutch fluid.....	153
Battery removal.....	154
Checking the electrolyte level.....	156
Charging the battery.....	156
Long periods of inactivity.....	157
Fuses.....	157
Front light group.....	161
Headlight adjustment.....	163
Front direction indicators.....	164
Rear optical unit.....	165
Rear turn indicators.....	165
Rear-view mirrors.....	165
Front and rear disc brake.....	167
Periods of inactivity.....	168
Cleaning the vehicle.....	170
Transport.....	175
TECHNICAL DATA.....	177
PROGRAMMED MAINTENANCE.....	185
Scheduled maintenance table.....	186
Recommended products.....	189

V100 Mandello - V100 Mandello S



Chap. 01
General rules

Carbon monoxide

CAUTION



EXHAUST EMISSIONS CONTAIN CARBON MONOXIDE, A POISONOUS GAS WHICH CAN CAUSE LOSS OF CONSCIOUSNESS AND EVEN DEATH.

CAUTION



CARBON MONOXIDE IS ODOURLESS AND COLOURLESS, THEREFORE IT CANNOT BE DETECTED BY SMELL, SIGHT OR OTHER SENSES. DO NOT BREATHE IN EXHAUST FUMES UNDER ANY CIRCUMSTANCES.

Fuel

CAUTION



FUEL USED TO DRIVE EXPLOSION ENGINES IS HIGHLY INFLAMMABLE AND CAN BECOME EXPLOSIVE UNDER SPECIFIC CONDITIONS. IT IS THEREFORE RECOMMENDED TO CARRY OUT REFUELLING AND MAINTENANCE PROCEDURES IN A VENTILATED AREA WITH THE ENGINE SWITCHED OFF. DO NOT SMOKE DURING REFUELLING OR NEAR FUEL VAPOUR. AVOID ANY CONTACT WITH NAKED FLAME, SPARKS OR OTHER HEAT SOURCES WHICH MAY CAUSE IGNITION OR EXPLOSION.

DO NOT ALLOW FUEL TO DISPERSE INTO THE ENVIRONMENT.

KEEP OUT OF THE REACH OF CHILDREN.



IF THE VEHICLE FALLS OR IS ON A STEEP INCLINE FUEL CAN LEAK.

Hot components

The engine and the exhaust system components get very hot and remain in this condition for a certain time interval after the engine has been switched off. Before handling these components, make sure that you are wearing insulating gloves or wait until the engine and the exhaust system have cooled down.

Warning lights



IF THE ALARM WARNING LAMPS ILLUMINATE DURING THE NORMAL ENGINE OPERATION, THIS MEANS THAT THE ELECTRONIC CONTROL UNIT HAS FOUND AN ABNORMALITY.



IF THE GENERAL ALARM WARNING LAMP FLASHES DURING THE NORMAL ENGINE OPERATION, THIS MEANS THAT THE OIL PRESSURE IN THE CIRCUIT IS INSUFFICIENT. IN THIS CASE THE ENGINE MUST BE SHUT OFF IMMEDIATELY IN ORDER TO PREVENT POSSIBLE DAMAGE.



PERFORM THE MOTOR OIL LEVEL CHECK. IF THE INSUFFICIENT MOTOR OIL PRESSURE LIGHT REMAINS DESPITE THE ABOVE PROCEDURE BEING PERFORMED CORRECTLY, CONTACT AN AUTHORIZED Moto Guzzi Dealer TO HAVE THE SYSTEM CHECKED.

Coolant

Coolant contains ethylene glycol, which may be flammable in certain conditions. Ethylene glycol burns with an invisible flame which may still cause burns.

CAUTION



TAKE PARTICULAR CARE NOT TO SPILL COOLANT ONTO HOT PARTS OR THE ENGINE AND EXHAUST SYSTEM; THE FLUID MAY IGNITE AND BURN WITH AN INVISIBLE FLAME. WHEN CARRYING OUT MAINTENANCE, IT IS ADVISABLE TO WEAR LATEX GLOVES. WHILE POISONOUS, COOLANT HAS A SWEET TASTE WHICH MAKES IT EXTREMELY APPEALING TO ANIMALS. NEVER LEAVE COOLANT IN OPEN CONTAINERS WHERE IT MAY BE REACHED AND DRUNK BY AN ANIMAL.

KEEP OUT OF THE REACH OF CHILDREN.

NEVER REMOVE THE RADIATOR CAP WHILE THE ENGINE IS STILL HOT. COOLANT IS UNDER PRESSURE AND MAY CAUSE BURNS.

Used engine oil and gearbox oil

CAUTION



WHEN CARRYING OUT MAINTENANCE OPERATIONS, IT IS ADVISABLE TO WEAR PROTECTIVE IMPERMEABLE GLOVES.

THE ENGINE OR GEARBOX OIL MAY CAUSE SERIOUS INJURIES TO THE SKIN IF HANDLED FOR PROLONGED PERIODS OF TIME AND ON A REGULAR BASIS.

WASH YOUR HANDS CAREFULLY AFTER HANDLING OIL.

HAND THE OIL OVER TO OR HAVE IT COLLECTED BY THE NEAREST USED OIL RECYCLING COMPANY OR THE SUPPLIER.

DO NOT DISPOSE OF OIL IN THE ENVIRONMENT

KEEP OUT OF THE REACH OF CHILDREN.

Brake fluid



BRAKE FLUID MAY BE HARMFUL TO PAINTWORK, PLASTIC AND RUBBER. WHEN SERVICING THE BRAKING SYSTEM, PROTECT THESE COMPONENTS WITH A CLEAN CLOTH. ALWAYS WEAR PROTECTIVE GOGGLES WHEN SERVICING THESE SYSTEMS. BRAKE FLUID IS EXTREMELY HARMFUL TO THE EYES. IN THE EVENT OF ACCIDENTAL CONTACT WITH THE EYES, RINSE THE EYES IMMEDIATELY WITH PLENTY OF COOL, CLEAN WATER AND SEEK IMMEDIATE MEDICAL ATTENTION.

KEEP OUT OF THE REACH OF CHILDREN.

Battery hydrogen gas and electrolyte

CAUTION



THE BATTERY ELECTROLYTE IS TOXIC, CORROSIVE AND, AS IT CONTAINS SULPHURIC ACID, MAY CAUSE BURNING IF IT COMES INTO CONTACT WITH THE SKIN. WHEN HANDLING BATTERY ELECTROLYTE, WEAR TIGHT-FITTING GLOVES AND PROTECTIVE APPAREL. IN THE EVENT OF SKIN CONTACT WITH THE ELECTROLYTIC FLUID, RINSE WELL WITH PLENTY OF CLEAN WATER. IT IS PARTICULARLY IMPORTANT TO PROTECT YOUR EYES BECAUSE EVEN TINY AMOUNTS OF BATTERY ACID MAY CAUSE BLINDNESS. SEEK SPECIALISED MEDICAL ATTENTION IMMEDIATELY IN THE EVENT OF CONTACT WITH THE EYES. THE BATTERY RELEASES EXPLOSIVE GASES; KEEP IT AWAY FROM FLAMES, SPARKS, CIGARETTES OR ANY OTHER HEAT SOURCES. ENSURE ADEQUATE VENTILATION WHEN SERVICING OR RECHARGING THE BATTERY.

KEEP OUT OF THE REACH OF CHILDREN.

BATTERY LIQUID IS CORROSIVE. DO NOT POUR OR SPILL ON PLASTIC COMPONENTS IN PARTICULAR. ENSURE THAT THE ELECTROLYTIC ACID IS COMPATIBLE WITH THE BATTERY BEING ACTIVATED.

Precautions general advice

DANGER OF OVERHEATING

WHEN THE VEHICLE IS STATIONARY, DO NOT KEEP THE ENGINE RUNNING MORE THAN NECESSARY, THIS MAY CAUSE EXCESSIVE OVERHEATING. IN EXTREME CASES, RISK OF FIRE.

- WHEN THE VEHICLE IS STATIONARY, DO NOT UNNECESSARILY RUN THE ENGINE.
- TO PREVENT DAMAGE FROM EXCESSIVE OVERHEATING, AUTOMATIC ENGINE SHUT-DOWN IS PROVIDED FOR LONG STAYS IN NEUTRAL,

AT IDLE SPEED, AND IN EXTREMELY HOT CONDITIONS. IN ANY CASE, EVEN AFTER THE AUTOMATIC SHUT-DOWN, THE ENGINE CAN BE SWITCHED ON AGAIN IMMEDIATELY.

- START IMMEDIATELY AFTER IGNITION, MAKING SURE TO RIDE A SHORT INITIAL DISTANCE AT LOW RPM.
- AFTER USE, AS SOON AS PARKED, THE ENGINE MUST BE IMMEDIATELY TURNED OFF.
- AFTER USE, DO NOT PLACE OBJECTS IN CONTACT WITH THE VEHICLE, WHEN IT IS STILL HOT, AS THEY COULD IGNITE (E.G. PROTECTIVE FABRICS, JACKET, ETC.).
- IF THE ENGINE TEMPERATURE IS VERY HIGH, IT IS POSSIBLE THAT THE COOLING FAN WILL CONTINUE TO RUN FOR SEVERAL SECONDS EVEN AFTER THE ENGINE HAS BEEN SWITCHED OFF. THIS BEHAVIOUR IS NOT TO BE CONSIDERED ABNORMAL, IT'S A STRATEGY SPECIFICALLY CREATED TO PROTECT THE ENGINE.

TAMPERING

- NEVER TAMPER WITH ANY PART OF THE MOTORCYCLE (E.G. ENGINE CONTROL UNIT, THROTTLE VALVES, CLUTCH, EXHAUST SYSTEM, ETC.). THIS MAY CAUSE DAMAGE TO THE COMPONENTS INVOLVED, FAILURE OF RELEVANT SAFETY FUNCTIONS AND LOSS OF THE WARRANTY.

DANGER OF BURNS

IN CASE OF OVERHEATING OF THE ENGINE AND EXHAUST SYSTEMS WHILE RUNNING, PAY PARTICULAR ATTENTION:

- DANGER OF BURNS:
- AFTER TURNING OFF THE VEHICLE, PAY ATTENTION THAT NO PERSON OR OBJECT COMES IN CONTACT WITH THE ENGINE AND THE EXHAUST SYSTEM.

Unless otherwise specified in this Use and Maintenance Manual, do not remove any mechanical or electrical component.

CAUTION

SOME CONNECTORS IN THE VEHICLE MAY BE ACCIDENTALLY SWAPPED AND MAY COMPROMISE NORMAL VEHICLE OPERATION IF INCORRECTLY INSTALLED.

V100 Mandello - V100 Mandello S



Chap. 02
Vehicle

Arrangement of the main components (02_01, 02_02)

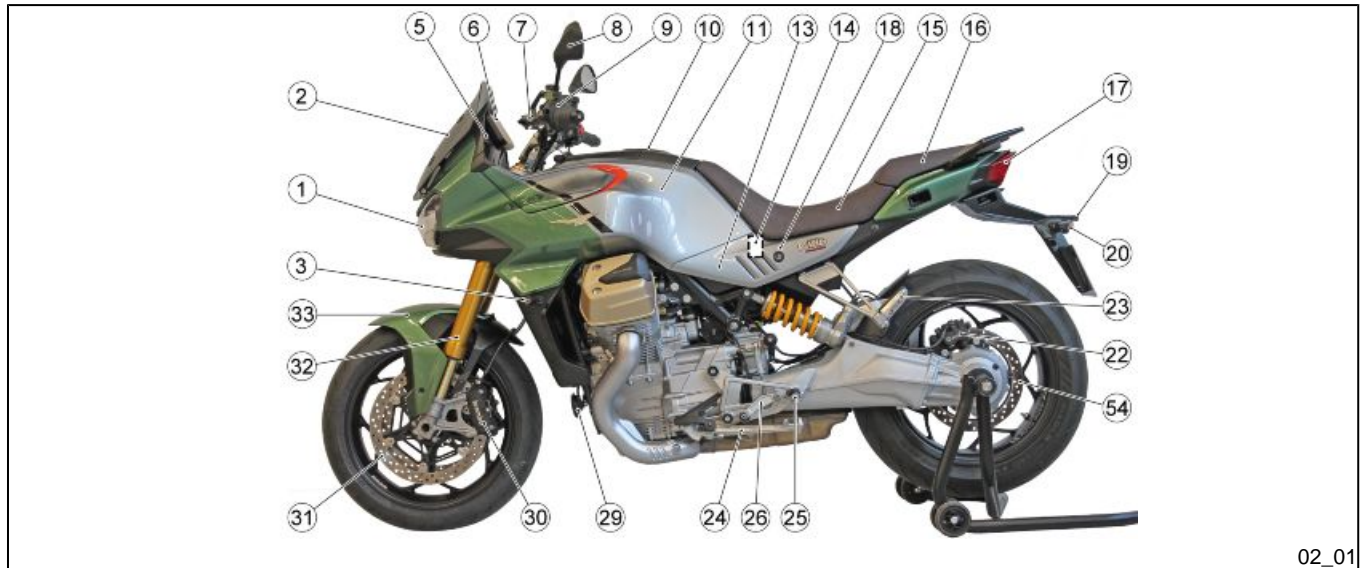

02_01

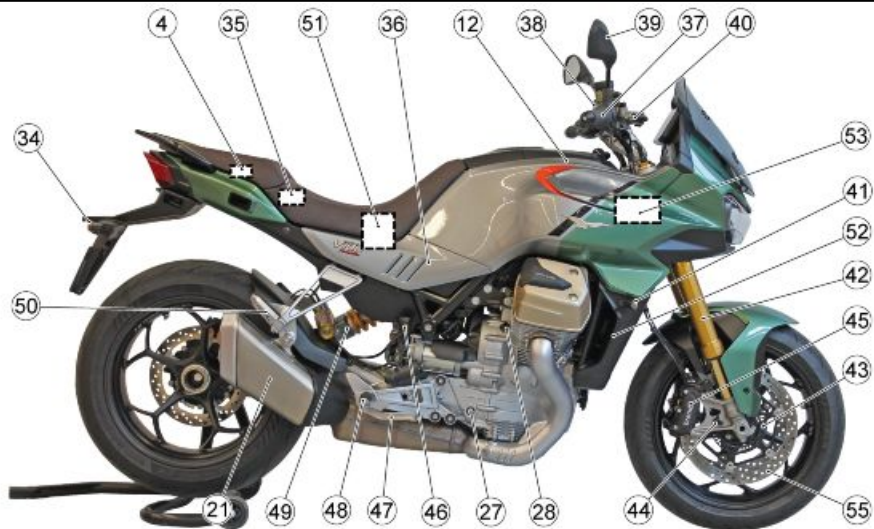

02_02

Key:

1. Headlamp
2. Adjustable windshield
3. Front left turn indicator
4. USB port
5. USB socket (where applicable)
6. Instrument panel
7. Clutch lever
8. Left rear-view mirror
9. Left light switch
10. Fuel tank cap
11. Fuel tank
12. Air filter
13. Left side fairing

14. Main fuses
15. Rider saddle
16. Passenger saddle
17. Taillight
18. Seat lock
19. Licence plate lamp
20. Rear left turn indicator
21. Silencer
22. Rear brake calliper
23. Passenger left footrest
24. Side stand
25. Left rider footrest
26. Gear shift lever
27. Engine oil level inspection port
28. Engine oil load cap
29. Horn
30. Front left brake calliper
31. Left hand front brake disc
32. Left fork stem
33. Front mudguard
34. Rear right turn indicator
35. Secondary fuses
36. Right side fairing
37. Throttle control
38. Right light switch
39. Right rear-view mirror
40. Front brake lever
41. Front right turn indicator
42. RH fork stanchion
43. Front tone wheel
44. Front tone wheel sensor
45. Front right brake calliper
46. Rear brake oil tank
47. Rear brake lever
48. Right rider footrest
49. Rear shock absorber (adjustable)
50. Right passenger footrest
51. Battery

- 52. Radiator
- 53. Radiator expansion tank
- 54. Rear brake disc
- 55. Right hand front brake disc

Dashboard (02_03)

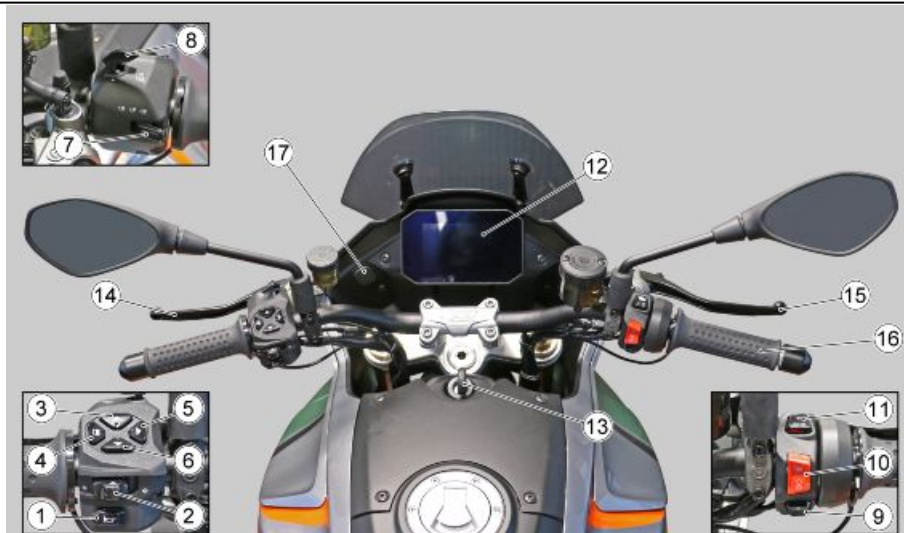

02_03

Key:

- 1. Audible warning device;

2. Turn indicator control;
3. Up button (MODE UP);
4. Set button (MODE SET);
5. Right button (MODE RIGHT);
6. Down button (MODE DOWN);
7. Low beam / high beam / flash high beam switch;
8. Cruise control selector;
9. Riding mode button;
10. Engine start / stop switch;
11. Daytime running lights (DRL) / night lights / additional headlights switch (where provided);
12. Instrument panel and indicators;
13. Ignition switch / steering lock;
14. Clutch lever;
15. Front brake lever;
16. Throttle grip;
17. USB socket (if provided).



Digital instrument panel (02_04, 02_05)

Key:

1. Multifunctional digital display box.
2. Indicator lights.



The dashboard has an immobilizer system which prevents start-up in case the system does not identify a key which has been stored before.

The vehicle is delivered to the customer with two pre-programmed keys. The dashboard accepts a maximum of four keys at the same time: contact an Official **Moto Guzzi** dealer to enable these keys or to disable a key that has been lost. Upon vehicle delivery, approximately ten seconds after the key is set to ON, the instrument cluster requests a personal five-digit code to be entered.

See the chapter "**Advanced functions**" for instructions on modifying the personal code

In case of code entry request, a box with variable values from 0 to 9 will be shown on the display using the MODE navigation buttons. Confirm the selection with a short press of the MODE SET button until completing the five digits; once all digits are entered, complete the operation by turning the ignition key to the OFF position.

It is important to remember the personal code because:

- **the vehicle can be started if the immobilizer system is faulty**
- **the dashboard need not be replaced should the ignition switch be changed**
- **new keys can be programmed**

NOTE

IF THE PERSONA CODE IS NOT MEMORISED AND THE VEHICLE IS USED, THE MESSAGE DISAPPEARS AFTER 10 SECONDS BUT REAPPEARS WITH EACH KEY ON.

NOTE

THE FACTORY SET CODE IS COMPOSED OF FIVE ZEROES.



Light unit (02_06)

Key:

1. MI warning light, orange;
2. High beam indicator lamp, blue;
3. Cruise control indicator lamp, green;
4. ABS indicator light, orange;
5. Left turn indicator warning light, green;
6. Right turn indicator warning light, green;
7. MGCT warning light, orange;
8. DRL indicator lamp, green;
9. Low fuel indicator light, orange;
10. Neutral indicator light, green;
11. Immobilizer / over-revs indicator lamp, red.

Digital lcd display (02_07, 02_08, 02_09, 02_10, 02_11, 02_12, 02_13, 02_14, 02_15, 02_16)

NOTE

THE INSTRUMENT CLUSTER IS EQUIPPED WITH A TWILIGHT SENSOR THANKS TO WHICH, BASED ON THE AMBIENT LIGHTING, CAN SWITCH FROM DAY TO NIGHT MODE.

IF THE "HEADLAMP MODE" FUNCTION (SEE PARAGRAPH "ADVANCED FUNCTIONS") IS SET TO THE "AUTO" STATUS, THE TWILIGHT SENSOR WILL SWITCH THE HEADLIGHT FROM D.R.L. TO LOW BEAM AND VICE-VERSA.

- Turning the ignition switch to 'KEY ON', the following illuminate on the dashboard for about two seconds:
 - A dynamic graphic presentation.
 - All indicator lights.



(where available)

If the GUZZI MIA ECU is present, pressing and holding the "MODE RIGHT" button accesses navigation mode.

Pressing and holding the button changes the digital display mode from ROAD to NAVI, and then to MENU.

Pressing and holding the MODE RIGHT button again scrolls through the "modes" available.

The following information is displayed in ROAD mode:

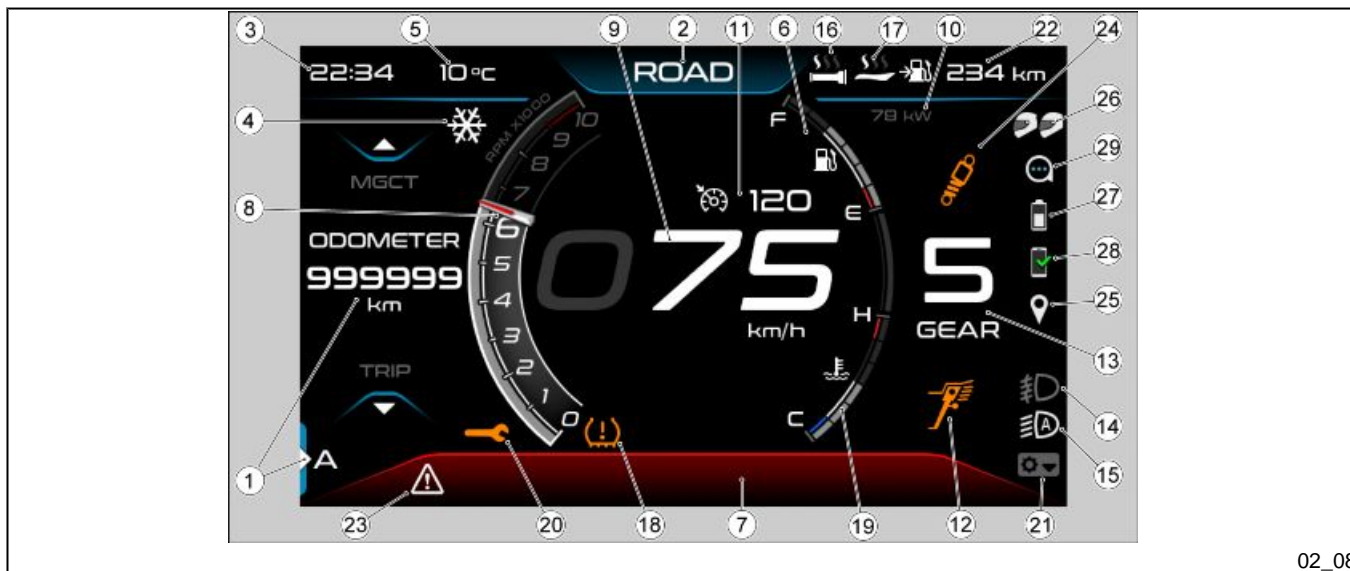

02_08

Key:

1) On-board computer log (TRIP LOG A / TRIP LOG B).

(Where the Guzzi Mia control unit is present: telephone, music, media player.

(Where the components are present): tyre pressure, heated handgrips, heated seat;

2) Riding mode active;

3) Clock (displayed in 24 or 12 hour mode, without the AM / PM indication);

4) Ice hazard icon (displayed at temperatures from -15 C° (5 F°) a $+3\text{ C}^{\circ}$ (37.4 F°)) / Battery warning indicator (voltage between poles too low) (both visible when alert conditions arise);

5) Ambient temperature (viewable in $^{\circ}\text{C}$ or $^{\circ}\text{F}$);

6) Fuel gauge;

7) Information pop-up area;

8) Engine speed (rpm x 1000);

9) Speed (speedometer) (displayed in km/h or in mph);

10) Reduced map indication (where required);

11) Cruise control speed (when the system is active, indicates the set cruise speed);

12) Open side stand indicator;

13) Gear selected;

14) Automatic lights mode active;

15) Fog lights active (where foreseen);

16) Hand grip heating level indicator;

17) Seat heating level indicator;

18) Low tyre pressure alarm (displayed where applicable);

- 19) Water temperature value (displayed in °C or °F);
- 20) Service icon;
- 21) Downshift status (displayed where implemented);
- 22) Driving in reserve (only when the reserve indicator is on) (displayed in km or mi);
- 23) General warning icon;
- 24) Suspension failure icon (V100 Mandello S)

Where the Guzzi Mia control unit is present:

- 25) GPS/Navigator (where active);
- 26) Rider/passenger intercom;
- 27) Battery level indicator relative to connected smartphone;
- 28) Audio transmission with smartphone for calling, sending vocal commands and playing music;
- 29) Data link with smartphone;

MAINTENANCE MESSAGE

When the maintenance time thresholds are exceeded, the icon depicting a wrench will appear, indicating the need to carry out scheduled maintenance on the vehicle.

This message can be reset once the scheduled maintenance has been completed by an **authorised Moto Guzzi Dealer or service centre**.





ICE HAZARD WARNING

At external temperatures between -15 °C (5 °F) and 3° C (37.4 °F), the ice hazard symbol appears on the display.



LOW BATTERY WARNING

The lighting of the battery symbol indicates a problem in the battery charging system.

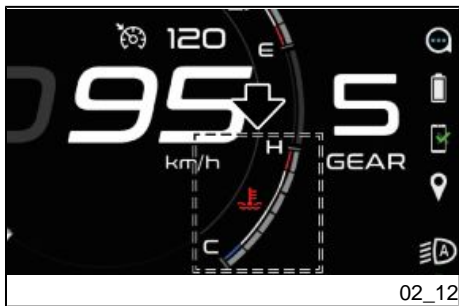

OVERTEMPERATURE WARNING

When the coolant temperature is 115 °F (239 °C) or higher: the temperature icon turns red and flashes together with the coolant temperature gauge.

CAUTION

STOP THE VEHICLE AND WAIT FOR THE ENGINE TO COOL.



FUEL LEVEL

The tank fuel level gauge is represented on the display by a number of bars.

When only the first bar remains on, it will change colour to orange, as does the symbol on the digital display. At the same time, the dedicated indicator light on the instrument panel comes on.

NOTE

IF THE RESERVE FUEL WARNING LAMP FLASHES AT KEY-ON, THIS INDICATES THAT THE FUEL LEVEL SENSOR IS DISCONNECTED.

IF THE FUEL SENSORS DO NOT WORK CORRECTLY, THE BARS MAY NOT BE DISPLAYED CORRECTLY. THEREFORE CONTACT AN Official Moto Guzzi Dealer.

NOTE

THE INDICATED FUEL LEVEL MAY VARY AND NOT BE DISPLAYED ACCURATELY IF THE MOTORCYCLE IS INCLINED (E.G. WHEN THE MOTORCYCLE IS PLACED ON THE SIDE STAND, OR IF VEHICLE IS RIDDEN ON LONG STRETCHES OF UPHILL OR DOWNHILL ROAD).



FUEL RANGE

When the vehicle is in reserve, the display shows the remaining range that can be covered in reserve (displayed in km or mi).

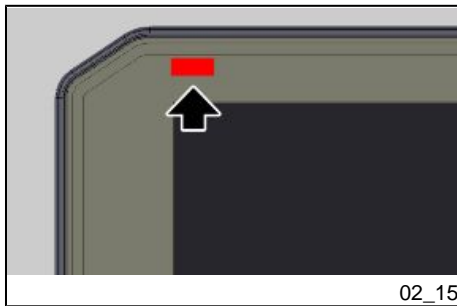

IMMOBILIZER

With the key in the "KEY OFF" position, the immobilizer indicator light flashes to indicate the activation of the system. To reduce battery consumption the light stops flashing after about 48 hours.



RIDING MODE SETTING SCREEN

The riding mode setting screen can be accessed from the main screen of the display, by pressing and holding the "RIDING MODE" button on the right hand handlebar control set.

See the paragraph "MGCT system" for instructions on modifying parameters.

Press "RIDING MODE" or "MODE SET" briefly to exit the setting mode screen.

NOTE

The MGCS item is only present on V100 Mandello S.



Alarms (02_17, 02_18, 02_19, 02_20, 02_21, 02_22, 02_23, 02_24, 02_25, 02_26, 02_27)

In the event of a fault, the Pop-up area of the digital display will turn red and a different message will be displayed depending on the cause.

Take your vehicle to an Official **Moto Guzzi** Dealer as soon as possible.

SERVICE ALARM

If there is a fault on the instrument panel or from the ECU, the instrument panel signals the fault by displaying the message "ALARM SERVICE" along with the general alarm icon.

If there is an immobilizer failure at ignition, the dashboard requests you to enter a user code. If the code is entered correctly, the dashboard signals the failure by displaying the message "ALARM SERVICE" along with the general alarm icon.



URGENT SERVICE ALARM

The serious anomaly is signalled by the rapid flashing (two flashes per second) of the message "URGENT SERVICE" accompanied by the general alarm icon in the Pop-up area which will turn red. Take your vehicle to an **Official Moto Guzzi Dealer** as soon as possible. In these cases the ECU activates a safety procedure limiting vehicle performance in order to allow the rider to go to an Official **Moto Guzzi Dealer** at a reduced speed.

Depending on the type of failure, performance can be limited in three ways: a) by reducing the maximum torque produced; b) by keeping the engine at idle speed but slightly accelerated (during this operation, the throttle control is disabled); c) the engine rpm is steady at around 3000 rpm; Under these conditions the throttle control provides limited management of the torque.

NOTE

THE PRESENCE OF THE "URGENT SERVICE" ERROR ON THE DIGITAL DISPLAY AND ACCOMPANIED BY THE FLASHING OF THE FOUR ARROWS FOR 30 SEC. TO WARN THE VEHICLES FOLLOWING OF A POSSIBLE DANGEROUS SITUATION, UNTIL THE TURN INDICATOR IS ACTIVATED TO ALLOW THE DRIVER TO PULL OVER .



Oil failure

In the event that an oil pressure anomaly is detected, the digital display will show the message "ALARM OIL PRESSURE" accompanied by the general alarm icon, all flashing in the Pop-up area which will turn red.



STOP THE VEHICLE AND CONTACT AN Approved Moto Guzzi dealer AS SOON AS POSSIBLE.



In the event that an oil pressure sensor anomaly is detected, the digital display will show the message "ALARM OIL SENSOR" accompanied by the fixed general alarm icon, in the Pop-up area which will turn red.

WARNING

TAKE YOUR VEHICLE TO AN Official Moto Guzzi Dealer AS SOON AS POSSIBLE.



MGCT disabled alarm

The MGCT system disabling alarm is activated when there is a problem that can cause the system itself to be disabled.

WARNING

DRIVE CAREFULLY AND CONTACT AN Official Moto Guzzi Dealer AS SOON AS POSSIBLE.



Immobilizer alarms

For immobilizer alarms, refer the specific paragraph "Immobilizer system operation". The error code may vary.

If there is an alarm, the user code must be entered to start the vehicle.

CAUTION

THE DISPLAY WILL SHOW THE ALARM MESSAGE, ACCOMPANIED BY THE GENERAL WARNING LIGHT, IN THE POP-UP AREA WHICH WILL TURN RED.

WARNING

DRIVE CAREFULLY AND CONTACT AN Official Moto Guzzi Dealer AS SOON AS POSSIBLE.



Electronic control unit disconnected alarm

If a lack of connection of the E.C.U. is detected, the instrument panel will signal the anomaly by displaying the message "ALARM CAN ECU DISCONNECTED" accompanied by the general alarm warning light in the Pop-up area which will turn red.

NOTE

THE MESSAGE "ALARM CAN ECU DISCONNECTED" REMAINS ON THE DIGITAL DISPLAY AND THE HAZARD WARNING LIGHTS WILL CONTINUE TO FLASH (TO WARN OTHER ROAD USERS BEHIND THE VEHICLE OF POTENTIAL DANGER) UNTIL THE RIDER ACTIVATES THE RIGHT HAND TURN SIGNAL TO INDICATE THAT THEY ARE ABOUT TO PULL OVER AND STOP.



"CAN BUS OFF" electronic control unit disconnected alarm

If a lack of connection with the CAN line is detected, the display will show the alarm message "ALARM CAN BUS OFF" accompanied by the general warning icon the Pop-up area which will turn red.

WARNING

DRIVE CAREFULLY AND CONTACT AN Official Moto Guzzi Dealer AS SOON AS POSSIBLE.



Headlamp disconnected alarm "CAN HLU"

If a lack of connection between the instrument panel and the headlight is detected, the display will show the alarm message "ALARM CAN HLU" accompanied by the general warning icon the Pop-up area which will turn red.

NOTE

THE FRONT TURN INDICATORS ALSO FLASH WHILE THE ERROR "ALARM CAN HLU" IS ACTIVE ON THE DIGITAL DISPLAY.

WARNING

DRIVE CAREFULLY AND CONTACT AN Official Moto Guzzi Dealer AS SOON AS POSSIBLE.



02_26

Brakes stuck alarm

In the event that constant pressure is maintained on at least one of the brake levers, with the vehicle moving at a speed equal to or greater than 10 Km/h (6 mph):

the display will show the alarm message "WARNING BRAKE STUCK" accompanied by the general warning icon and the Pop-up area will turn orange.



02_27

Brakes stuck alarm

If the pressure is maintained for more than 60 seconds, with the vehicle moving at a speed equal to or greater than 10 Km/h (6 mph):

the display will show the alarm message "ALARM BRAKE STUCK" accompanied by the general warning icon and the Pop-up area will turn red.

CAUTION

IF THE ALARM MESSAGE DOES NOT DISAPPEAR WHEN RELEASING THE BRAKE LEVERS, STOP THE VEHICLE AND CONTACT AN Official Moto Guzzi Dealer FOR DIAGNOSIS AND TROUBLESHOOTING OF THE BRAKE SYSTEM.



02_28

Mapping selection (02_28, 02_29, 02_30, 02_31)

The engine control unit has 4 different selectable "riding modes" for managing the electronic accelerator, displayed as follows in the upper central part of the digital display:

- **SPORT**
- **ROAD**
- **TOUR**
- **RAIN**

The **SPORT** mode is designed for a more dynamic use of the vehicle. The throttle response is rapid, engine braking and traction control are minimally invasive.

The **ROAD** mode is designed for urban use. Engine response is less aggressive and engine braking is more invasive than in **SPORT** mode, while traction control is set to the intermediate level.

The **TOUR** mode is designed for a touristic use of the vehicle. The engine response is less aggressive, the engine brake and traction control are set to the intermediate level.

The **RAIN** mode is intended for use on surfaces with poor traction. The engine response is mild, the engine brake is efficient and the traction control is set to the maximum level.

All of the "riding modes" listed above can be configured by the user, as shown in the "ADVANCED FUNCTIONS" section.

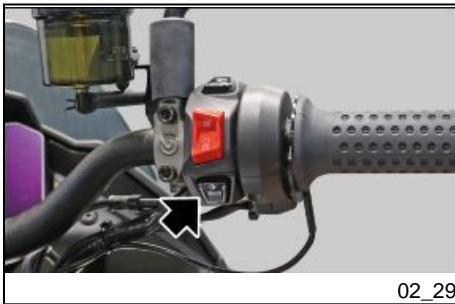

02_29

To cycle through the different riding modes, press the button shown in the figure on the right hand handlebar control set briefly.

CAUTION

DIFFERENT RIDING MODES MAY ALSO BE SELECTED ON THE FLY WHILE THE VEHICLE IS MOVING, PROVIDED THAT THE THROTTLE GRIP IS RELEASED.

RIDING MODES MAY ALSO BE PRESELECTED WHILE THE THROTTLE IS OPEN. IN THIS CASE, THE NEW MODE IS ONLY EFFECTIVELY IMPLEMENTED WHEN THE THROTTLE IS CLOSED AGAIN. IN THIS CASE THE ICON AND THE NAME OF THE RIDING MODE WILL FLASH.



02_30

CAUTION

IF THE THROTTLE IS OPENED WHILE THE NEW RIDING MODE IS SHOWN IN FLASHING MODE ON THE DISPLAY (I.E. MODE IS PRESELECTED ONLY AND PENDING IMPLEMENTATION BY THE ECU), THE PRESELECTED NEW RIDING MODE WILL NOT BE EFFECTIVELY IMPLEMENTED UNTIL THE THROTTLE GRIP IS RELEASED.

IF A NEW RIDING MODE IS SELECTED WHILE THE THROTTLE IS OPEN, THE NEW RIDING MODE REQUESTED WILL BE SHOWN IN FLASHING MODE UNTIL THE THROTTLE GRIP IS RELEASED.

CAUTION

IF THE REQUESTED RIDING MODE CONTINUES TO BE DISPLAYED IN FLASHING MODE, THIS MEANS THAT NOT ALL THE CONDITIONS NECESSARY FOR IMPLEMENTATION OF A NEW MODE ARE MET, E.G.: THROTTLE OPEN, CLUTCH LEVER IN USE ETC.



02_31

To gain access to the riding mode settings screen, press and hold the relative button on the right hand lights switch.

Using the "MODE UP" or "MODE DOWN" buttons, the desired parameter may be selected and by briefly pressing the "MODE RIGHT" button, the intervention value can be increased.

Once the maximum level is reached, the setting will restart from the minimum intervention value.

After setting the parameters as desired, press "MODE SET" briefly to exit the screen.

Press and hold "MODE SET" to restore the factory settings.

NOTE

The MGCS item is only present on V100 Mandello S.

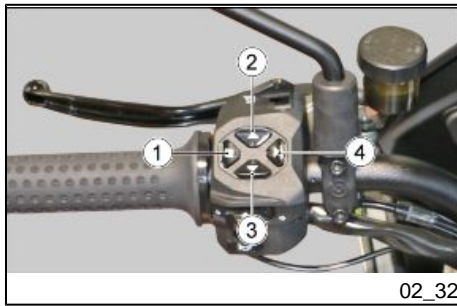

02_32

Control buttons (02_32, 02_33, 02_34, 02_35, 02_36, 02_37, 02_38, 02_39, 02_40, 02_41, 02_42, 02_43, 02_44, 02_45, 02_46, 02_47, 02_48, 02_49, 02_50, 02_51, 02_52, 02_53, 02_54, 02_55)

The control buttons on the left hand light switch may be used to navigate within the different screens of the system, view trip A / B log information and, if the vehicle is equipped with the GMP unit (Guzzi Multimedia Platform), also access phone information and music and media content.

The navigation buttons are as follows:

1. **MODE SET** (select / confirm / press and hold to reset)
2. **MODE UP** (up)
3. **MODE DOWN** (down)
4. **MODE SET** (right)



02_33

Using the "cruise" selector on the left-hand light switch is it possible to:

- Increase or decrease the cruise control set speed;
- Within the MGCT function, change the traction control intervention level only if the **CRUISE CONTROL IS NOT ACTIVE**.



02_34

A number of different symbols (such as the examples (1) and (2) shown in the figure) may be displayed in the pop-up space.

- Where shown as a solid shape (1), the symbol indicates that it is necessary to press and hold the relative control for the function described.
- Where shown as an outline only (2), the symbol indicates that it is necessary to press the relative control briefly and release for the function described.

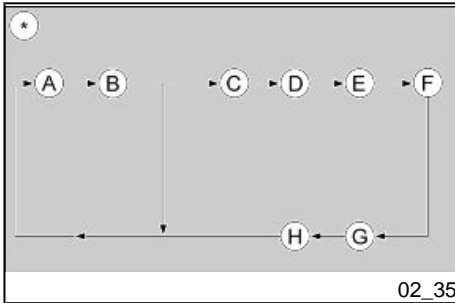

02_35

When in ROAD mode (*), pressing "MODE RIGHT" briefly repeatedly cycles through the following screens:

- A) Trip log A.
- B) Trip log B.
- C) Heated hand grip info (where provided)
- D) Heated saddle information (where provided)
- E) Tyre pressure info (where provided)
- F) Phone information. (if applicable)
- G) Music information. (if applicable)
- H) Multimedia information. (if applicable)

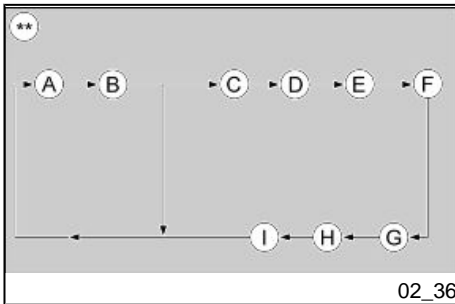

02_36

When in NAVI mode (*), pressing "MODE RIGHT" briefly repeatedly cycles through the following screens:

- A) Trip log A.
- B) Trip log B.
- C) Heated hand grip info (where provided)
- D) Heated saddle information (where provided)
- E) Tyre pressure info (where provided)
- F) Phone information. (if applicable)
- G) Music information. (if applicable)
- H) Multimedia information. (if applicable)
- I) Navigation information. (if applicable)



A) - B) Trip log (displayed in ROAD / NAVI modes)

There are two trip logs available, log A and log B.

Press "MODE UP" or MODE DOWN" button briefly to cycle through the following information on the digital display, in the indicated order:

- ODOMETER.
- TRIP ODOMETER.
- TRIP TIME.
- MAXIMUM SPEED.
- AVERAGE SPEED.
- AVERAGE FUEL CONSUMPTION.
- INSTANTANEOUS FUEL CONSUMPTION.
- DRIVING IN RESERVE (only when the reserve indicator is on).
- MGCT (Moto Guzzi Traction Control)

From any of the following view modes: TRIP ODOMETER, TRIP TIME, MAXIMUM SPEED, AVERAGE SPEED or AVERAGE FUEL CONSUMPTION, press and hold MODE SET to reset all the values logged in the currently active TRIP LOG.



C) Heated grips information (displayed in ROAD / NAVI modes) (where provided)

This menu provides information about the heated grips including the activation status and the heating intensity.

For further details, see paragraph "Heated grips control".



D) Heated saddle information (displayed in ROAD / NAVI modes only) (where applicable)

This menu provides information about the heated saddle, including the activation status and the heating intensity.

For further details, see paragraph "Heated saddle control".



E) Tyre pressure information (displayed in ROAD and NAVI modes) (where provided)

Select this screen to view information relative to tyre pressure and temperature and possible alarms.



F) Phone information (where provided)

Information relative to phone calls is displayed in this menu, such as:

- Call in progress.
- Incoming call.
- Outgoing call.
- Call ended.
- Voice control active.
- Call log.

See the chapter "ADVANCED FUNCTIONS" for more details.



G) Music information (displayed in ROAD / NAVI modes) (where provided)

Information relative to audio playback is displayed in this menu, such as:

- Track playing.
- Playback paused.

See the chapter "ADVANCED FUNCTIONS" for more details.



H) Media information (where provided)

The vehicle is equipped with the "**MOTO GUZZI MIA**" accessory, which communicates with the smartphone via Bluetooth. Using the specific "**MOTO GUZZI**" application installed on the smartphone, it is possible to exchange data with the vehicle and manage multimedia contents. Once a connection is established correctly between the control unit and smartphone, the following functions can be directly managed by the digital display of the vehicle:

- call management;
- manage audio playback;
- GPS navigation.



The "**MULTIMEDIA**" sub-menu of the main "**MENU**" contains 3 functions:

- Devices status (list of paired devices)
- Reset pairing (reset of all paired devices)
- Devices pairing (allows the pairing of new devices)

Having activated the Bluetooth function on the device to be paired, by briefly pressing the MODE RIGHT button, selecting the "Devices pairing" command from the vehicle menu, the devices available for pairing will be scanned.

Once the device to be paired has been identified, after selecting it, by briefly pressing the MODE RIGHT button, pairing will be carried out and the screen will return to the



ROAD mode display with a pop-up confirming "PAIRING COMPLETED" or "PAIRING ABORTED" if the pairing does not take place correctly



The smartphone icon on the display indicates active communication. **When requested, allows phone book and notifications sharing. These enabling operations are necessary to display the caller's name on the display.**

NOTE

UPON THE FIRST PAIRING BETWEEN THE DISPLAY AND SMARTPHONE, MORE TIME MAY BE REQUIRED FOR THE SYNCHRONIZATION OF THE PHONE BOOK.

THE CONNECTION BETWEEN THE SMARTPHONE AND VEHICLE WILL BE SIGNALLED BY THE LIGHTING OF THE SMARTPHONE ICON ON THE DISPLAY.

CAUTION

TO PAIR THE DEVICES IT IS NECESSARY TO ACTIVATE THE PAIRING OF THE DEVICES AND THEN LAUNCH THE OPERATION FROM THE INSTRUMENT PANEL.



CONNECTION BETWEEN THE APPLICATION AND THE DIGITAL DISPLAY

Search for the "**Moto Guzzi**" application in Play Store or App Store and install it. Register your account by following the instructions. Select "**allow**" for the position and notifications management requests.

PAIRING A BLUETOOTH HEADSET FROM THE APP

Multimedia functions may be accessed using the MODE buttons if a bluetooth headset is paired with the digital display using the "**Moto Guzzi**" app. (This can also be performed from the instrument panel without using the application). After pairing it will be possible to answer or reject calls, activate voice commands and control the music on the smartphone.

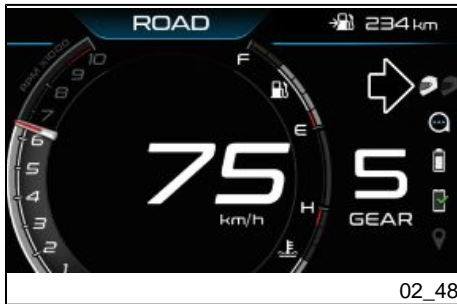

Activate the "**pairing**" mode of the bluetooth headset to be paired (refer to the instructions of the device itself). Press the Bluetooth icon on the main screen of the "**Moto Guzzi**" application and perform a new search for devices until the headset is displayed. Select the bluetooth headset, check the "**Handsfree/driver headset**" option and press "**Pair**". Successful pairing is indicated by the helmet icon displayed on the digital display. If the pairing is not successful, perform a new search.

Repeat the operation to connect a second device also. If this pairing procedure is successful, the 2nd helmet icon will be highlighted in black on the digital display.



No multimedia function can be managed from the handlebar of the vehicle if there is no bluetooth headset, or if the headset is directly connected to the smartphone. **The Bluetooth headset can be paired with the vehicle only via the "Moto Guzzi" application and it must be connected to the vehicle in order to correctly use the multimedia functions of the system. For this reason, the headsets that automatically connects to the smartphone are not compatible (Ex: Apple AirPods).**

If pairing between Smartphone and Vehicle is not successful, proceed as follows:

- restart the smartphone;
- turn the ignition key to "**OFF**" and then to **ON**"; wait for the animation on the display to end.

If the smartphone icon on the display is not illuminated after approximately 1 minute, proceed as follows;

- open "**Moto Guzzi**" and select "**Connect**";
- select your vehicle from the list of suggestions and follow the instructions on the device;
- once the Application is connected, select the Bluetooth icon that appears on the main screen;
- open the Bluetooth devices menu;
- select "**Configure**" and delete all paired devices, leaving the current device till last, or perform the operation from the vehicle **MENU**;
- make sure that the application icon on the display is off;
- turn the ignition key to "**OFF**" and then to "**ON**", then wait until the animation on the screen ends;
- the display must show the pop up "**No connected device**";
- repeat the pairing procedure from the start.

NOTE

PLEASE NOTE THAT TO CONNECT THE APP TO THE VEHICLE AGAIN, THE FOLLOWING WILL BE NECESSARY:

- ON iOS, DELETE THE PREVIOUSLY INSTALLED APP AND REINSTALL IT.
- ON ANDROID, SIMPLY DELETE THE APPLICATION DATA FROM THE APP MANAGEMENT MENU (THIS WILL RETURN THE APPLICATION TO THE INITIAL CONDITION AND THE LOGIN AND FIRST CONNECTION TO THE VEHICLE MUST BE PERFORMED AGAIN).
- IN CASE OF CONNECTION TO A NEW VEHICLE, IT IS NECESSARY TO REMOVE THE PREVIOUS BT-ROUTER FROM THE ASSOCIATED DEVICES.

NOTE

IT IS RECOMMENDED TO PAIR A MAXIMUM OF 2 SMARTPHONES AND 2 HEADSETS TO THE SAME VEHICLE, TO OPTIMIZE THE OPERATION OF THE SYSTEM.

IN CASE OF PAIRING THE SECOND SMARTPHONE, NOTE THAT THE SECOND ONE WILL REQUIRE A LONGER TIME (MORE THAN 30 SECONDS) TO CONNECT TO THE "BT-ROUTER". ONCE THE SMARTPHONE IS CONNECTED TO THE "BT-ROUTER", THE OPERATING SYSTEM WILL REQUEST ACCESS TO THE PHONE BOOK AND TO THE NOTIFICATIONS; ACCEPT TO DISPLAY THE NAMES OF THE CALLERS ON THE DISPLAY.

Required operation for iOS 10.0 versions or higher

If the "BT-ROUTER" device does not automatically request permission to share notifications, the following procedure is necessary:

- Enter the menu: "Settings" > "Bluetooth" > "Phone devices";
- select "**BT-ROUTER**", select "Info", enable the options manually.

INTERCOM AND VOCAL COMMANDS MANAGEMENT

The "Moto Guzzi" system manages the connection between the intercom and smart-phone upon activation by the user.



FOR SAFETY REASONS, IT IS RECOMMENDED TO CARRY OUT THE ACTIVATION / DEACTIVATION PROCEDURES WITH THE VEHICLE AT A STANDSTILL.

To activate the "INTERCOM" function, press and hold the MODE SET button from the "Media information" screen.

A pop-up with the message "INTERCOM ON" will be shown on the digital display.



The audio volume may now be controlled by pressing and holding MODE UP or MODE DOWN.



Pressing the MODE SET button briefly again deactivates the connection. The state "INTERCOM OFF" is now shown on the digital display.



To activate the "VOICE" function, which allows the user to access and use functions of their smartphone with voice commands from the headset (e.g. via Siri or Google Assistant), select the function with the MODE UP or MODE DOWN buttons and then press MODE SET briefly.



THE "VOICE" FUNCTION CANNOT BE ACTIVATED IF THE "INTERCOM" FUNCTION IS ALREADY ACTIVATED.

I) Navigation information (displayed in NAVI mode only) (where applicable)

Select this screen to view the destination for the navigation system entered via the smartphone.

" Guzzi MIA" SYSTEM MESSAGES

The "Guzzi MIA" system communicates with the user through messages that can be viewed on the graphic panel of the digital display. Depending on the message type, the graphic panel shows the icon, colours and the specific message.



The following information is displayed:

- Information messages related to the infotainment system.

CALL MANAGEMENT

To use phone features, view caller notifications and identifiers, it is necessary to:

- pair the smartphone with the "Guzzi MIA" system via Bluetooth, as previously described;
- install the "Moto Guzzi" app on your smartphone and access it (can be performed also from the instrument panel, without using the application);
- pair a bluetooth headset with the "Guzzi MIA" system using the "Moto Guzzi" app (or from the dashboard instrument panel, without using the application);
- allow sharing of the phonebook and notifications when the smartphone is paired with the "Guzzi MIA" system.

NOTE

WHEN A SMARTPHONE CONNECTS WITH THE «MOTO GUZZI MIA» SYSTEM (BT-ROUTER), AUDIO IS AUTOMATICALLY ROUTED TO THE MOTO GUZZI MIA SYSTEM.

IF THERE IS NO HEADSET CONNECTED TO THE "MOTO GUZZI MIA" SYSTEM, THE AUDIO FUNCTION OR MUSIC PLAYBACK CANNOT BE MANAGED, THEREFORE THE SMARTPHONE AUDIO MUST BE MANUALLY ROUTED TO THE DESIRED DEVICE (E.G. SPEAKERS/TELEPHONE MICROPHONE).

The following information is shown in the relative area on the digital display:

- call in progress;
- call ended;
- voice control active;
- incoming call;
- outgoing call;
- call log.

Press and hold MODE SET to enable voice commands.

Press MODE DOWN or MODE UP briefly to scroll through the log of all calls (missed calls, calls made, outgoing calls made with no reply).

Select the required log entry and then press and hold MODE SET to call the relative contact.

MODE SELECTOR FUNCTIONS FOR CALL MANAGEMENT

Accept incoming call	PRESS MODE SET BRIEFLY
End an active call	PRESS AND HOLD MODE SET
Reject incoming call	PRESS AND HOLD MODE SET
Cancel outgoing call	PRESS AND HOLD MODE SET
Activate volume control (with call in progress)	PRESS AND HOLD MODE UP OR MODE DOWN
Increase volume (with call in progress)	PRESS MODE UP BRIEFLY
Lower volume (with call in progress)	PRESS MODE DOWN BRIEFLY

MANAGING A SECOND CALL

If the smartphone paired with the "Guzzi MIA" system is capable of receiving a second incoming call, a number of functions for managing a second call are available.

A popup appears on the digital display showing the identification details of the current and of the new incoming call are displayed in alternation (at intervals of approximately 1 second).

FUNCTIONS OF MODE SELECTOR FOR MANAGING SECOND CALL

Accept incoming call and put current call on hold	PRESS MODE SET BRIEFLY
Reject incoming call and continue current call	PRESS AND HOLD MODE SET
Switch between call 1 and call 2	PRESS MODE SET BRIEFLY



MUSIC PLAYBACK MANAGEMENT

To use the functions of the music player, the following must be performed:

- pair the smartphone with the "**Guzzi MIA**" system via Bluetooth, as previously described;
- install the "**Moto Guzzi**" app on your smartphone and access it (can be performed also from the instrument panel, without using the application);
- pair a bluetooth headset with the "**Guzzi MIA**" system using the "**Moto Guzzi**" app (or from the dashboard instrument panel, without using the application).

The corresponding three icons are shown on the digital display.

NOTE

WHEN A SMARTPHONE CONNECTS WITH THE «MOTO GUZZI MIA» SYSTEM (BT-ROUTER), AUDIO IS AUTOMATICALLY ROUTED TO THE MOTO GUZZI MIA SYSTEM.

IF THERE IS NO HEADSET CONNECTED TO THE "MOTO GUZZI MIA" SYSTEM, THE AUDIO FUNCTION OR MUSIC PLAYBACK CANNOT BE MANAGED, THEREFORE THE SMARTPHONE AUDIO MUST BE MANUALLY ROUTED TO THE DESIRED DEVICE (E.G. SPEAKERS/TELEPHONE MICROPHONE).

The following information appears on the digital display:

- track playing;
- playback paused;
- playback interrupted.

Use the MODE buttons to manage audio playback as shown in the table:

MODE SELECTOR FUNCTIONS FOR MUSIC MANAGEMENT

Play track	PRESS MODE SET BRIEFLY
Activate volume control (with call in progress)	PRESS AND HOLD MODE UP OR MODE DOWN
Increase volume (with call in progress)	PRESS MODE UP BRIEFLY
Lower volume (with call in progress)	PRESS MODE DOWN BRIEFLY
Next music track	PRESS MODE UP BRIEFLY
Previous audio track	PRESS MODE DOWN BRIEFLY
Activate Siri	PRESS AND HOLD MODE SET

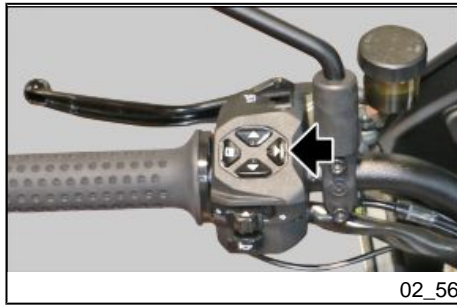

Advanced functions (02_56, 02_57, 02_58, 02_59, 02_60, 02_61, 02_62, 02_63, 02_64, 02_65, 02_66, 02_67, 02_68, 02_69, 02_70, 02_71, 02_72, 02_73, 02_74, 02_75, 02_76, 02_77, 02_78, 02_79, 02_80, 02_81, 02_82, 02_83, 02_84, 02_85, 02_86, 02_87, 02_88, 02_89, 02_90, 02_91, 02_92, 02_93, 02_94, 02_95, 02_96, 02_97)

With a long press of the MODE RIGHT button, from the ROAD screen, the display will pass to the NAVI screen (if the Guzzi MIA ECU is present) and then to the MENU screen.

The flow diagram below shows the structure of the menu; the submenus of each function are explained in the relevant paragraphs in this section.

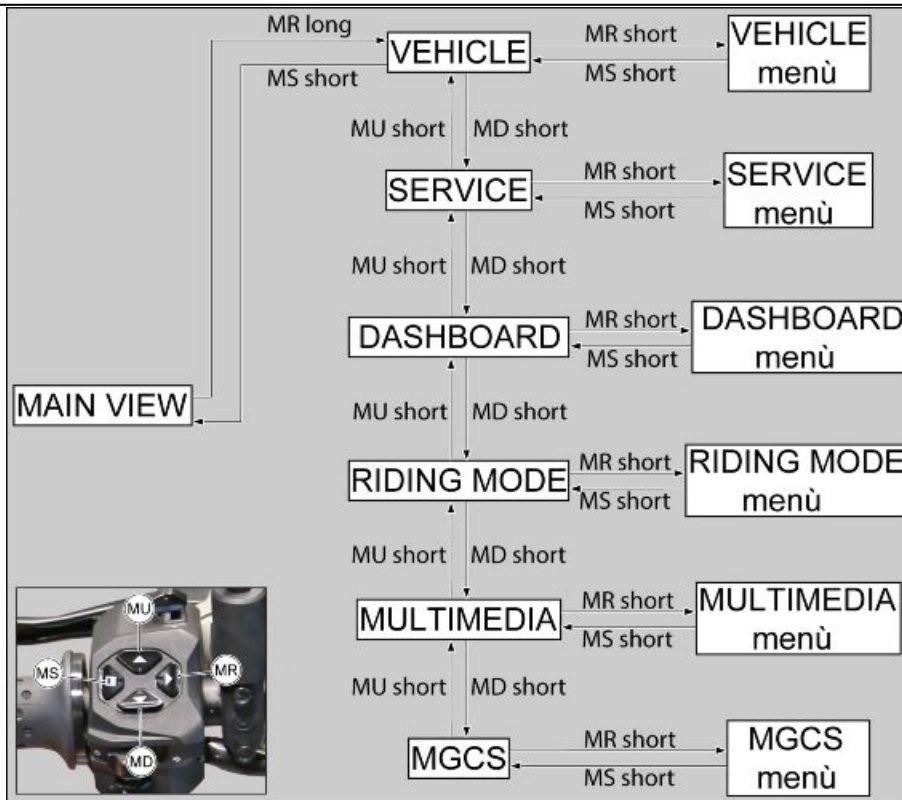



The menu is composed of the following entries:

- 1) Vehicle
- 2) Service
- 3) Instrument cluster
- 4) Riding mode
- 5) Multimedia - **where required**
- 6) MGCS (Moto Guzzi Suspension Control) - **where required**



1) Vehicle

The "Vehicle" menu contains the following options:

- 1.1) Headlamp mode - **where required**
- 1.2) Shift light
- 1.3) MGQS down - where required
- 1.4) Emergency brake (Stop light)
- 1.5) Calibration (Calibration)
- 1.6) LCDAS (Rear Radar) - (**if applicable**)

The functions available in the "Vehicle" menu are described in the following paragraphs.

Press MODE SET briefly to go back to the main MENU.



1.1) Headlamp mode - where required

This function is used to set the operating mode of the lights.

The use mode can be selected by shortly pressing the MODE RIGHT button. These modes will be displayed cyclically every time you press the button.

Auto = Automatic

Manual = Manual

Emergency = Emergency; (emergency mode must only be used in the event of a malfunction of the headlamp; and enables usage of the low beam headlights and DRL lights only)

Press MODE SET briefly to go back to the main MENU.

NOTE

THE RELATIVE ICON IS SHOWN ON THE DIGITAL DISPLAY WHEN "AUTO" MODE IS ACTIVE.



1.2) Shift light

This function is used to set the rotation threshold; if this is exceeded, the engine rpm bar will flash and the immobilizer indicator light will switch on.

The threshold can be increased by shortly pressing the MODE RIGHT button.

Once the maximum rotation number is reached, the threshold starts again from 4000 rpm.

Press MODE SET briefly to exit edit mode.



02_62

1.3) MGQS down - where required

This function may be used to enable or disable the automatic matching system allowing downshifts without using the clutch.

The activation status can be changed by briefly pressing the button. The function will be cyclically changed by further pressing the MODE RIGHT button.

Press MODE SET briefly to go back to the main MENU.

MGQS ICON KEY:

- White icon = MGQS active
- Grey icon = MGQS disabled by user
- Orange icon = MGQS disabled by system
- Red icon = MGQS system malfunction



02_63

1.4) Emergency brake (Stop light)

When enabled, this function automatically activates the hazard warning lights in the event of hard and/or sudden braking. Activation of the hazard warning lights is not dependent on whether the ABS system is triggered.

If it is not active, a brief press on the MODE RIGHT button will activate the function and a further press will deactivate it again.

Press MODE SET briefly to go back to the main MENU.



02_64



1.5) Calibration (Calibration)

When the Calibration function is selected (with the vehicle stationary), having activated it by pressing the MODE RIGHT button briefly, a screen appears in the Pop-up area with the following description:

"Calibration - Speed not correct"



To calibrate the MGCT system (Moto Guzzi Traction Control) ride along a flat straight road in second gear at a speed of 40 ± 2 km/h (24.85 ± 1.24 mph) for approximately 10 seconds, until the digital display shows a message "Calibration running Hold speed".



02_68

If calibration is completed successfully, the message "Calibration done - Key OFF (60s)" is displayed.

NOTE

WHEN THE TEXT "Calibration done - Key OFF (60s)" APPEARS ON THE DISPLAY, STOP THE VEHICLE AND TURN THE IGNITION TO KEY-OFF FOR AT LEAST 60 SECONDS TO COMPLETE CALIBRATION.

THIS ALLOWS THE CALIBRATION TO BE STORED IN THE MEMORY.

NOTE

THE CALIBRATION OPERATION IS USED TO OPTIMISE THE MGCT FUNCTION IN CASE OF A CHANGE IN TYRE TYPE.

IF TYRES OTHER THAN THOSE INDICATED IN THIS USE AND MAINTENANCE BOOKLET ARE USED, TO OBTAIN THE SAME PERFORMANCE FROM THE MGCT SYSTEM THE SETTING LEVELS OF THE SYSTEM ITSELF MAY NEED TO BE MODIFIED.

NOTE

TURN THE IGNITION SWITCH OFF TO ABORT THE CALIBRATION PROCEDURE.

DURING CALIBRATION, ATC IS AUTOMATICALLY DEACTIVATED (IF PREVIOUSLY ACTIVATED).

1.6) LCDAS (Rear Radar) - (where required)

This menu allows you to activate or deactivate the radar by setting it to "ON" or "OFF". Press MODE SET briefly to go back to the "Dashboard" menu.



02_69



This function signals the presence of obstacles approaching from the rear of the vehicle, both right and left, by means of light signals on the display and on the relative rear-view mirror.

2) Service

The "Service" menu contains the following options:

- 2.1) Change user code
- 2.2) Code recovery
- 2.3) Windshield
- 2.4) Application (Firmware version)
- 2.5) Boot loader (Firmware version)

2.6) HLU application (Firmware version)

The functions available in the "Service" menu are described in the following paragraphs.

Press MODE SET briefly to go back to the main MENU.



2.1) Change user code

This function may be used to modify the existing code (you must be in possession of the code itself in order to do this). The user code enables engine start even in the event of an immobiliser system fault. On a new vehicle, the user code is set by default as five zeros (00000) and the message "INSERT YOUR PERSONAL CODE" appears on the display for ten seconds when the ignition is switched on.

This function allows you to change the code itself and remove this message.

The leftmost value of the display will show a value from 0 to 9 (which can be changed by pressing the MODE UP or MODE DOWN keys). Press MODE SET briefly to confirm the selection. Repeat the operation for all the digits. Once the code is confirmed, the new code is shown steadily on the display to let the user verify that the code has been entered correctly. Turn the ignition off and then on again to unlock the dashboard. The last code set may be modified again in the future. Access the setting mode again, enter the last user code used (OLD CODE), then enter a new user code (NEW CODE) as described previously.

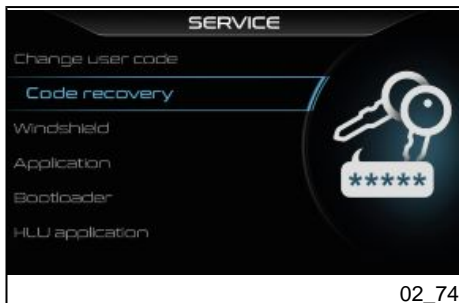

2.2) Code recovery

This function must be used should it be necessary to change the user code when the user no longer remembers the code currently in use. Both keys stored in the vehicle memory are needed to access this function.

Once the function is activated, pressing the MODE SET briefly displays the message "INSERT KEY 1", requesting identification of the first key. Insert the key. If the correct key is recognised within twenty seconds, the message "INSERT KEY 2" is shown on the display. Insert the second key. If the second key is also recognised within twenty



seconds, the dashboard resets the user code to the default code (five zeros - 00000). Enter the new user code following the "CHANGE USER CODE " procedure.

2.3) Windshield

This function also allows you to set the maximum speed at which the top fairing can be adjusted while riding, differentiating the setting for the two versions:

- SMALL: the top fairing can be adjusted up to a maximum speed of 130 km/h or 80 mph.
- BIG: the top fairing can be adjusted up to a maximum speed of 110 km/h or 68 mph.

CAUTION

THESE LIMITS MAY BE REDUCED UNDER CERTAIN ENVIRONMENTAL CONDITIONS.

3) Instrument cluster

The "Dashboard" menu contains the following options:

- 3.1) Backlight
- 3.2) Clock (Clock)
- 3.3) Units (Units)
- 3.4) Language
- 3.5) Riding modes language

The functions available in the "Dashboard" menu are described in the following paragraphs.



3.1) Backlight (Backlight)

This function allows you to change the backlight of the digital display, from a minimum value of 1 to a maximum value of 10.

The back light intensity can be increased with one point by briefly pressing on the MODE RIGHT button. Once the maximum level is reached, a further press will restart the setting from the minimum value.

Keep the MODE RIGHT button pressed to continuously increase the value until the button is released.

Press MODE SET briefly to go back to the main MENU.



3.2) Clock (Clock)

This menu allows to adjust the clock and change its display format. The menu is divided into the following items:

3.2.1) Minutes (Minutes)

3.2.2) Hours (Hours)

3.2.3) 12 H or 24 H mode (12 H or 24 H display)

Press MODE SET briefly to go back to the "Dashboard" menu.

3.2.1) Minutes / 3.2.2) Hours / 3.2.3) 12H or 24H mode (12H or 24H display)

For the Minutes and Hours functions only, the value can be increased with one point with a brief press on the MODE RIGHT button. Once the maximum level is reached, a further press will restart the setting from the minimum value. Keep the MODE RIGHT button pressed to continuously increase the value until the button is released

For the 12H or 24H mode function only (12H or 24H display), briefly press the MODE RIGHT selector to change the time display format.

Press MODE SET briefly to go back to the "Clock" menu.



3.3) Units (Units)

This menu allows you to change the settings for displaying the units and is divided as follows:

- 3.3.1) Speed (Speed)
- 3.3.2) Fuel consumption (Fuel consumption)
- 3.3.3) Temperature (Temperature)
- 3.3.4) Pressure (visible where applicable)

Press MODE SET briefly to go back to the "Dashboard" menu.

3.3.1) Speed (Speed)

This function may be used to change the unit of measurement used for speed:

- km/h (kilometres per hour)
- mph (miles per hour)

The measurement unit can be changed by shortly pressing the MODE RIGHT button.

Press MODE SET briefly to go back to the "Dashboard" menu.

NOTE

IF THE UNIT OF MEASURE SET AT THE FACTORY HAS BEEN CHANGED, THE SPEED'S UNIT OF MEASURE WILL FLASH FOR 30 SECONDS EACH TIME THE KEY IS ENGAGED.

3.3.2) Fuel consumption (Fuel consumption)

This function is used to change the display of the fuel consumption measurement unit:

- km/l
- l/100 km
- mpg (UK)
- mpg (USA)

The measurement unit can be selected by shortly pressing the MODE RIGHT button. These units will be displayed cyclically every time you press the button.

Press MODE SET briefly to go back to the "Dashboard" menu.

3.3.3) Temperature (Temperature)

This function is used to change the measurement unit used for temperature:

- °C (Celsius degrees)
- °F (Fahrenheit degrees)

The measurement unit can be changed by shortly pressing the MODE RIGHT button.

Press MODE SET briefly to go back to the "Dashboard" menu.

3.3.4) Pressure (visible where applicable)

This function is used to change the display of the tire pressure measurement unit:

- bar;
- psi.

The measurement unit can be changed by shortly pressing the MODE RIGHT button.

Press MODE SET briefly to go back to the "Dashboard" menu.

3.4) Language

This function is used to change the instrument panel display language:

- English
- Italian
- French
- German
- Spanish





The next language can be selected by shortly pressing the MODE RIGHT button. These languages will be displayed cyclically every time you press the button.

Press MODE SET briefly to go back to the "Dashboard" menu.

3.5) Riding modes language (Riding modes display language)

This function is used to change the Riding mode display language:

- Italian
- English

The next language can be selected by shortly pressing the MODE RIGHT button.

Press MODE SET briefly to go back to the "Dashboard" menu.

4) Riding mode (Riding mode) - where required

Each "Riding mode" is composed of the following entries:

MGCM (Moto Guzzi Engine Control)

MGCT (Moto Guzzi Traction Control)

MGCA (Moto Guzzi Aerodynamic Control) - **where required**

MGCS (Moto Guzzi Suspension Control) - **where required**

This function allows to edit the intervention level of each individual control system associated with the Riding mode selected.

Using the MODE RIGHT button, select the RIDING MODE you want to edit, then use the MODE UP or MODE DOWN buttons to position on the item of which you want to edit and change the intervention level using the MODE RIGHT button.

For more information on the available settings, refer to the "**MGCT System**" section.

To reset the values to the factory settings, select the desired RIDING MODE and press and hold the MODE SET button.

	SPORT	ROAD	TOUR	RAIN
MGCM	1	2	1	2
MGCT	2	1	OFF	4
MGCA	ON 30 <small>km/h</small>	OFF	ON	ON -- <small>km/h</small>
MGCS	M1 ←	M2 ←	A2 ←	A1 ←
	MODIFY ▸	MOVE ◆	RESET ■	EXIT □

02_83

Press MODE SET briefly to go back to the main MENU.

NOTE

Intervention RANGE

MGCM: 1 - 3 (1 = more aggressive intervention, 3 = softer intervention)

MGCT: OFF - 4 (4 = maximum intervention)

MGCA: you can select the speed at which the aerodynamic protections will open.

MGCS: M1, M2, A1, A2. (M = manual, A = automatic)



5) Multimedia (Multimedia)

The "Multimedia" menu consists of the following items:

- 5.1) Devices status
- 5.2) Devices pairing
- 5.3) Reset pairing (Delete pairing)

The functions available in the "Multimedia" menu are described in the following paragraphs.

Press MODE SET briefly to go back to the main MENU.

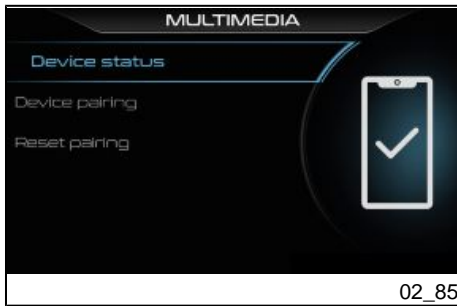

5.1) Devices status

The "Devices status" menu allows to view the list of paired devices.

Press MODE SET briefly to return to the "Multimedia" menu.



5.2) Devices pairing

The "Devices pairing" menu allows to pair new devices.

Press MODE SET briefly to return to the "Multimedia" menu.



5.3) Reset pairing (Delete pairing)

The "Reset pairing" menu allows to delete and consequently disconnect all paired devices.

Press MODE SET briefly to return to the "Multimedia" menu.



6) MGCS (Moto Guzzi Suspension Control) - where required

The MGCS menu allows you to adjust the parameters of the OHLINS electronic suspension based on the preferences of the rider and the use conditions of the vehicle.

The changes made will be effective on all Riding modes.

The MGCS menu consists of the following entries:

6.1) Manual dynamic / Manual comfort

6.2) Automatic dynamic / Automatic comfort



6.1) Manual dynamic / Manual comfort

These menus allow modifying the suspension settings in "manual" mode, by operating electronically on the hydraulic settings. Each of the two modes is preset by the parent company and it is always possible to return to the factory settings.

The editable parameters in these two modes are the following:

- Front compression
- Front rebound
- Rear compression
- Rear rebound

Once the parameter to be modified has been highlighted, using the MODE UP / DOWN buttons, it is possible to increase it by one point by briefly pressing the MODE RIGHT button.

Keep the MODE RIGHT button pressed to continuously increase the value until the button is released. Once the maximum setting value has been reached, the count will restart from the minimum value.

With a long press of the MODE SET button, the selected parameter will be reset to the factory value.



The "compression/extension" parameters can be modified from minimum 1 (HARD) to a maximum 31 (SOFT) (one unit corresponds to one click of a traditional suspension)

Briefly press on the MODE SET button to return to the "MGCS" menu.

6.2) Automatic dynamic / Automatic comfort

The automatic modes actively adapt the suspension and relative adjustments based on the vehicle's behaviour in relation with the riding style. Each of the two modes is preset by the parent company and it is always possible to return to the factory settings.

The editable parameters in these two modes are the following:

- Front firmness (front damping)
- Rear firmness (rear damping)
- Brake support (brake assistance)

Once the parameter to be modified has been highlighted, using the MODE UP / DOWN buttons, it is possible to increase it by one point by briefly pressing the MODE RIGHT button.

Keep the MODE RIGHT button pressed to continuously increase the value until the button is released. Once the maximum setting value has been reached, the count will restart from the minimum value.

With a long press of the MODE SET button, the selected parameter will be reset to the factory value.

The values can be modified from a minimum of -5 (SOFT) to a maximum of +5 (HARD).

Briefly press on the MODE SET button to return to the "MGCS" menu.



GPS NAVIGATION (where applicable)

Combined with the "MOTO GUZZI" application, the "MOTO GUZZI MIA" system allows the display of GPS indications on the digital display. By means of pictograms, distance and travel time data, the desired destination can be reached. The navigation icon appears on the digital display after setting the destination address.

Refer to the navigation guide by accessing the "MOTO GUZZI" application with your account.

Press and hold down MODE RIGHT to access the GPS navigation directions and information screen.

NOTE

BY SETTING THE DESTINATION ADDRESS VIA THE "MOTO GUZZI" APPLICATION, THE DIGITAL DISPLAY AUTOMATICALLY DISPLAYS THE INDICATION SCREEN.

NOTE

"SHORT PRESS": PRESS THE BUTTON AND RELEASE WITHIN 0.5 SECONDS;

"PRESS AND HOLD": PRESS THE BUTTON AND HOLD FOR AT LEAST 2 SECONDS.



02_92

Navigation screen key:

1) Trip log (A / B) / Navigation information

(If the Guzzi MIA ECU is present): telephone, music, media player.

(Where the components are present): heated seat, heated handgrips;

2) Riding mode selected;

3) Clock (displayed in 24 or 12 hour format, without the AM / PM indication);

4) Ice hazard icon (displayed at temperatures from -15 °F (5 °C) to +3 °F (37.4 °C)) / Battery alert indicator (voltage between poles too low);

5) Ambient temperature (viewable in °F or °C);

- 6) Fuel gauge;
- 7) Indication regarding the manoeuvre after next manoeuvre and the relative distance;
- 8) distance remaining to arrival at destination;
- 9) time remaining to arrive at destination;
- 10) Destination address / Information pop-up;
- 11) indication of the next turn and relative distance;
12. Rpm indicator;
- 13) Speed (speedometer) (displayed in km/h or in mph);
- 14) Gear selected (displayed only with engine running and vehicle moving);
- 15) Automatic lights mode active;
- 16) Fog lights active (where foreseen)
- 17) Open side stand indicator;
- 18) Water temperature value (displayed in °C or °F);
- 19) Downshift status (where implemented);
- 20) Low tyre pressure alarm;
- 21) Driving in reserve (only when the reserve indicator is on) (displayed in km or mi);
- 22) Indication regarding the speed limit applicable on the current road;
- 23) Suspension failure icon (V100 Mandello S);
- 24) Service icon;
- 25) Hand grip heating level indicator;
- 26) Seat heating level indicator;
- 27) Reduced power map indication (where required);.

In the space dedicated to navigation information it is possible to view:

- If not navigating, the list of the last destinations started (if any) is present;
- If navigating, the current destination is present.

ELECTRONIC CONTROLS OF THE VEHICLE

Moto Guzzi V100 is equipped with an advanced integrated electronic control system that helps improving the performance and the rider's safety.

The system consists of:

MGCM: Moto Guzzi Engine Control;

MGCT: Moto Guzzi Traction Control;

MGCA: Moto Guzzi Aerodynamic Control;

MGCS: Moto Guzzi Suspension Control (where required);

MGQS: Moto Guzzi Quick Shift (where required);

TPMS: Tire Pressure Measurement System (where required) - (see "Tires" section).

MGCM

Moto Guzzi Engine Control is the system that controls engine power delivery:

- Level 1 has an aggressive delivery and is suitable for performance use and expert riders.
- Level 3 has a gentle and progressive delivery of power and is recommended for use in poor grip / wet conditions. The vehicle is more easily handled.

ABS

The ABS with CORNERING is a device to avoid the wheels locking in case of emergency braking also when cornering, thus increasing vehicle stability when braking when compared with a traditional braking system.

The CORNERING mode takes into account the motorcycle's lean angle, so as to maximise efficiency without endangering the rider.

The ABS system improves vehicle control provided that the physical limits of vehicle grip on the road are not exceeded. The rider is fully responsible for riding at a suitable speed based on weather and road conditions, always leaving an appropriate safety margin.

Under no circumstances can the ABS system compensate for the rider's misjudgement or improper use of brakes.

NOTE

WHEN THE ABS STARTS WORKING, A PULSING IS FELT ON THE BRAKE LEVER.



THE ANTI-LOCK BRAKING SYSTEM OF THE WHEEL DOES NOT PREVENT FALLS WHILE CORNERING.

AN EMERGENCY BRAKING WITH THE VEHICLE INCLINED, HANDLEBAR TURNED, ON UNEVEN OR SLIPPERY ROADS, OR WITH POOR GRIP, CREATES A LACK OF STABILITY DIFFICULT TO HANDLE. RIDE CAREFULLY AND SENSIBLY AND ALWAYS BRAKE GRADUALLY.

DO NOT SPEED RECKLESSLY. THE VEHICLE GRIP ON THE ROAD IS SUBJECT TO LAWS OF PHYSICS WHICH NOT EVEN THE ABS SYSTEM CAN ELIMINATE.



When the vehicle is started, after the initial instrument panel check cycle, the ABS warning lamp flashes until the vehicle reaches a speed of 3.1 mph (5 km/h), after which it goes out.

If the ABS warning lamp lights steadily or continues to flash even after exceeding a speed of 5 km/h (3.1 mph), this means that a fault has been detected and that the ABS system has been disabled.

In this case carry out the following operations:

- stop the vehicle;
- Key OFF-ON;
- ride the vehicle to a speed above 5 km/h (3.1 mph): the ABS warning light must be turned off;
- the ABS system is working.

If the ABS disabled indication remains:

NOTE

IF THIS OCCURS, CONTACT AN OFFICIAL Moto Guzzi dealer.

CAUTION

If the ABS warning light flashes more frequently than that of the initial check, it means that there is a problem with the IMU inertial platform, which will not provide information to any of the vehicle control systems.

In this case the MGCT traction control is deactivated, therefore riding the vehicle will be extremely dangerous. DRIVE WITH THE MAXIMUM CAUTION AND CONTACT AN Official Moto Guzzi Dealer.

NOTE

IN THE EVENT OF A PROLONGED ROTATION OF THE REAR WHEEL WITH THE FRONT WHEEL LOCKED (BURNOUT, MOTORCYCLE PLACED ON THE CENTRAL STAND, ETC.) THE SYSTEM CAN BE AUTOMATICALLY DEACTIVATED WHEN THE ABS AND THE MGCT ABD ABS INDICATORS ARE SWITCHED ON STEADY. TO REACTIVATE, TURN THE IGNITION SWITCH OFF AND THEN ON AGAIN AND SELECT THE REQUIRED SETTING.

NOTE

THE SAFETY PROVIDED BY THE ABS DOES NOT, IN ANY CASE, JUSTIFY RISKY MANOEUVRES. EVEN THOUGH THE ABS SYSTEM ENSURES GREATER VEHICLE CONTROL IN THE EVENT OF EMERGENCY BRAKING, ALWAYS OBSERVE THE CORRECT MINIMUM SAFETY DISTANCE FROM THE VEHICLE IN FRONT OF YOU.



THE ABS SYSTEM USES SIGNALS RECEIVED FROM THE TWO TONE WHEELS (FRONT AND REAR) TO CONTROL THE PRESSURE APPLIED TO BOTH BRAKES. IT IS IMPORTANT TO ALWAYS CHECK THAT THE TONE WHEEL IS IN PERFECT CONDITION, AND PERIODICALLY CHECK THAT THE DISTANCE FROM THE SENSOR IS CONSTANT OVER THE ENTIRE 360 DEGREES. WHEN REMOVING AND REFITTING THE FRONT WHEEL, IT IS VERY IMPORTANT TO ENSURE THAT THE GAP BETWEEN THE TONE WHEEL AND THE SENSOR AND THE PARALLEL ALIGNMENT BETWEEN THE TWO COMPONENTS ARE AS

SPECIFIED. FOR CHECKING AND ADJUSTMENT, CONTACT AN Authorised Moto Guzzi Garage.



WHERE THE MOTORCYCLE HAS AN ABS SYSTEM, NON-APPROVED BRAKE PADS AND TYRES COMPROMISE SMOOTH BRAKING, DRASTICALLY REDUCING DRIVING SAFETY.

NOTE

THE SYSTEM'S SENSORS, HAVING A SIGNIFICANT ACCURACY OF READING THE TONE WHEELS, MAY GENERATE, A MOTORCYCLE STOPPED AND THE ENGINE RUNNING, INDICATION OF SPEED OF SOME km / h (mph) ON THE DIGITAL DISPLAY.

SUCH BEHAVIOUR IS TO BE CONSIDERED NORMAL AND DOES NOT CREATE MALFUNCTIONS IN THE SYSTEM.



IF THE DISTANCE OF THE FRONT SENSOR IS NOT INCLUDED IN THE INTERVAL LISTED BELOW, CONTACT AN Official Moto Guzzi Dealer.

Characteristic

Distance between tone wheel and front sensor

0.5 - 1.50 mm (0.020 - 0.059 in)

Moto Guzzi Traction Control

Traction control: is a system developed to control the relative skidding of the wheels and help the rider to have greater control and safety of the vehicle.

The MGCT system also intervenes in an optimal manner during cornering, thus controlling skidding in this stage of the ride.

This is made possible by the inertia sensor platform, which provides the ECU with precise information concerning the inclination of the motorcycle.

MGCT SYSTEM DEACTIVATED MANUALLY

At key-on and after the initial dashboard check cycle, if the system is deactivated, the MGCT indicator light remains lit and fixed until the rider activates the system again.

MGCT SYSTEM ACTIVE

At key-on and after the initial instrument cluster check cycle, the MGCT indicator light flashes slowly if the system has remained active since the previous use. The light will turn off once 3.1 mph (5 km/h) is exceeded.

If the MGCT indicator light is on permanently it means that a malfunction was detected and the traction control is automatically deactivated. At the same time as the indicator light comes on, the message "MGCT DISABLED" will be shown in the Pop-up area of the display

In this case carry out the following operations:

- stop the vehicle;
- Key OFF-ON;
- reactivate the system manually
- ride the vehicle to a speed above 5 km/h (3.1 mph): the MGCT indicator light must turn off;
- MGCT is working.

If the MGCT disabled message remains:

NOTE

IF THIS OCCURS, CONTACT AN OFFICIAL Moto Guzzi dealer.



THE MGCT SYSTEM ACTS ON THE REAR WHEEL ON THE BASIS OF INFORMATION RECEIVED FROM TONE WHEELS INSTALLED ON BOTH WHEELS. IT IS IMPORTANT TO ALWAYS CHECK THAT THE TONE WHEEL IS IN PERFECT CONDITION, AND PERIODICALLY CHECK THAT THE DISTANCE FROM THE SENSOR IS CONSTANT OVER THE ENTIRE 360 DEGREES. WHEN REMOVING AND REFITTING THE FRONT WHEEL, IT IS VERY IMPORTANT TO ENSURE THAT THE GAP BETWEEN THE TONE WHEEL AND THE SENSOR AND THE PARALLEL ALIGNMENT BETWEEN THE TWO COMPONENTS ARE AS SPECIFIED. FOR CHECKING AND ADJUSTMENT, CONTACT AN Authorised Moto Guzzi Garage

NOTE

IN THE EVENT OF A PROLONGED ROTATION OF THE REAR WHEEL WITH THE FRONT WHEEL LOCKED (BURNOUT, MOTORCYCLE PLACED ON THE CENTRAL STAND, ETC.) THE SYSTEM CAN BE AUTOMATICALLY DEACTIVATED WHEN THE ABS AND THE MGCT ABD ABS INDICATORS ARE SWITCHED ON STEADY. TO REACTIVATE, TURN THE IGNITION SWITCH OFF AND THEN ON AGAIN AND SELECT THE REQUIRED SETTING.

NOTE

THE MGCT SENSORS, HAVING A HIGH ACCURACY OF THE TONE WHEEL READINGS, CAN GENERATE A SPEED INDICATION OF SEVERAL km/h (mi) ON THE DIGITAL DISPLAY WHEN THE MOTORCYCLE IS STOPPED AND THE ENGINE IS RUNNING.

SUCH BEHAVIOUR IS TO BE CONSIDERED NORMAL AND DOES NOT CREATE MALFUNCTIONS IN THE MGCT SYSTEM.

Characteristic

Distance between tone wheel and front sensor

0.5 - 1.50 mm (0.020 - 0.059 in)

The system is active by default. However, if the system has been deactivated, in order to reactivate it, the user must access the specific screen using the selector button on the right hand handlebar control set

Using the MODE navigation buttons, select level 1 if the level was set to 0.

If the MGCT system is activated when the vehicle is stationary, the relative indicator light will flash until 3.1 mph (5 km/h) is reached.

Press the MODE UP or MODE DOWN buttons briefly to increase or decrease the MGCT level setting from "1" (minimum system control) to "4" (maximum system control).

Using the MGCT/Cruise control command (if the cruise control is not active) it is possible to modify the control value of the MGCT system directly from the main screen, in all riding modes.

The MGCT value is changed (from 1 to 4) with short up or down presses of the control.

From level 1, the MGCT is permanently disabled with a long press downwards.

To reset the MGCT, make a long or short push upwards.

NOTE

THIS IS ALSO POSSIBLE WITH THE MOTORCYCLE IN MOTION.

CAUTION

TO GAIN FAMILIARITY WITH THE MGCT SYSTEM, PREFERABLY USE LEVEL "4" TO START WITH, THEN TRY THE OTHER LEVELS TO IDENTIFY WHICH ARE THE BEST SUITED TO YOUR RIDING STYLE AND FOR DIFFERENT ROAD AND WEATHER CONDITIONS.

LEVEL "1" IS RECOMMENDED FOR EXPERT RIDERS IN IDEAL ROAD SURFACE CONDITIONS.

THE OTHER LEVELS INCREASE THE INTERVENTION OF THE MGCT SYSTEM, UP TO THE MAXIMUM INTERVENTION OF LEVEL "4".

To deactivate the system, set the control level to "OFF".

The MGCT warning light will be on steady.

CAUTION

IF THE MGCT SYSTEM IS DEACTIVATED, A POP-UP WITH THE MESSAGE "MGCT DISABLED" IS SHOWN ON THE DIGITAL DISPLAY TO WARN THE RIDER THAT THERE IS NO TRACTION CONTROL ASSISTANCE.

THIS POP-UP CLEARS AFTER 5 SECONDS.

NOTE

THIS IS ALSO POSSIBLE WITH THE MOTORCYCLE IN MOTION.

NOTE

ONCE THE IGNITION SWITCH IS TURNED OFF, AT THE NEXT START UP THE MGCT SYSTEM MAINTAINS THE PREVIOUSLY SELECTED SETTINGS.

Moto Guzzi Aerodynamic Control

This system regulates the deployment of the aerodynamic deflectors on the tank and guarantees the protection of the rider from turbulence.

The system can be set to ON or OFF, or the vehicle speed at which the deflectors will deploy can be set to a range from 30 km/h to 80 km/h or from 20 mph to 50 mph.

The speed at which the deflectors are deployed can be adjusted by short presses of the MODE UP and MODE DOWN buttons.

This setting is individually selectable for each of the riding modes.

Moto Guzzi Suspension Control (where required)

This vehicle is equipped with an ÖHLINS Smart EC 2.0. system.

The system is composed of front suspension, rear suspension and control unit (Suspension Control Unit).

MGCS provides preset damping levels, optimized for various conditions, both for the front and rear suspensions.

Through the control unit that receives signals from the various control units of the vehicle, the front and rear suspensions are constantly updated data on the driving conditions.

This results in an optimized compression and extension damping, based on the vehicle's behaviour during driving. The system permanently adjusts the compression and extension damping levels according to the circumstances.

Furthermore the spring pre-load of the front and rear suspension can be manually adjusted.



PAY SPECIFIC ATTENTION WHEN DISCONNECTING THE CONNECTORS, TO AVOID DAMAGING THEM, WHICH WOULD COMPROMISE THE OPERATION OF THE VEHICLE.

There are two modes, Automatic and Manual:

- **A1 - Automatic dynamic** Mode specific for sportive road use.
- **A2 - Automatic comfort** Mode specific for road use aimed at comfort.
- **M1 - Manual dynamic** Mode specific for sportive road use.
- **M2 - Manual comfort** Mode specific for road use aimed at comfort.

For each mode, the control type of the MGCS system can be modified.

Depending on the selected mode, the following parameters can be modified:

- **Front firmness (front damping)**: Control that allows balancing the front suspension between comfort and stability. An adjustment aimed at comfort

improves the filtering of the road bumps and the shock absorption; vice versa, an adjustment aimed at stability, increases the dampening of the movements.

- **Front compression:** Energy absorption control when the front suspension is compressed. Therefore, the compression is adjusted when the front wheel is subjected to a load.
- **Front rebound:** Energy absorption control when the front suspension is in extension phase. It adjusts the speed with which the suspension returns to the normal position after having been compressed.
- **Rear firmness (rear damping):** Control that allows balancing the rear suspension between comfort and stability. An adjustment aimed at comfort improves the filtering of the road bumps and the shock absorption; vice versa, an adjustment aimed at stability, increases the dampening of the movements.
- **Rear compression:** Energy absorption control when the rear shock absorber is compressed. Therefore, the compression speed is adjusted when the rear wheel is subjected to a load.
- **Rear rebound:** Energy absorption control when the rear suspension is in extension phase. It adjusts the speed with which the suspension returns to the normal position after having been compressed.
- **Brake support (brake assistance):** Energy absorption control when the vehicle is braking, based on the set resistance value, the load variation and consequently offering better control.

FACTORY SETTINGS TABLE

Parameters	A1 - Automatic dynamic	A2 - Automatic comfort	M1 - Manual dynamic	M2 - Manual comfort
Front firmness	0	-5	-	-
Front compression	-	-	28	31
Front extension	-	-	5	20
Rear firmness	0	-5	-	-
Rear compression	-	-	30	31
Rear extension	-	-	10	15
Brake support	0	-5	-	-

NOTE

The adjustment ranges of the registers vary between "Automatic" and "Manual" and are:

"Automatic": -5 (Soft) / +5 (Hard)

"Manual": 1 (Hard) / 31 (Soft)

(Soft): the hydraulic brake is at its minimum value. When referred to the compression, the suspension will be softer; when referring to rebound, the suspension return will be faster.

(Hard): the hydraulic brake is at its maximum value. When referred to the compression, the suspension will be harder; when referring to rebound, the suspension return will be slower.



CAUTION

IN CASE OF AN ELECTRICAL ANOMALY OR IF A SUSPENSION CONNECTOR IS DISCONNECTED, THE SUSPENSION ICON WILL FLASH ON THE DIGITAL DISPLAY TO INDICATE A MALFUNCTION OF THE MGCS SYSTEM.

THEREFORE, RIDE CAREFULLY AND IMMEDIATELY CONTACT AN OFFICIAL Moto Guzzi DEALER.

CAUTION

EVEN IF A FAULT IS SIGNALLED AND THEREFORE WHEN THERE IS NO ELECTRONIC SUSPENSION MANAGEMENT, THEY WILL NOT LOSE THEIR TRADITIONAL MECHANICAL FUNCTIONALITY.

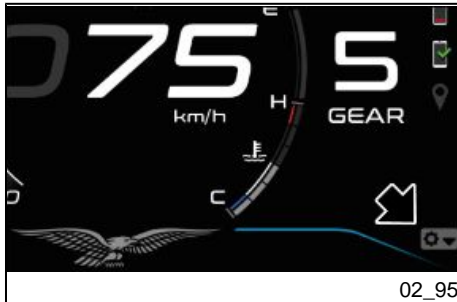

Moto Guzzi Quick Shift (where required)

It is a system that allows go up and down the gears without having to use the clutch 'and without changing the position of the throttle grip.

It uses the gear shift sensor signal on the gear lever to shift gears more quickly with a lower decrease in rpm than a traditional gear shift as regards upshifting.

The system is only active above an engine speed: of approximately 2000 rpm.

CAUTION

THE CLUTCH MUST BE USED FOR UPSHIFTS AT ENGINE SPEEDS BELOW 2000 rpm.

CAUTION

THE SYSTEM IS ACTIVE WHEN SHIFTING UP ONLY WITH THE THROTTLE OPEN.



It can operate when downshifting as long as all the required conditions are met, including an rpm less than the maximum threshold, which varies according to the gear. If the downshifting system is not available temporarily for some reason (e.g. RPM too high, first gear engaged), the instrument panel icon will be orange.

If the icon lights red, it means that the electronic Quick Shift system is disabled due to a problem.

In this case carry out the following operations:

- Stop the vehicle;
- perform key OFF-ON;
- ride the vehicle to a speed above 5 km/h (3.1 mph): the warning light must turn off;
- the MGQS is now functional.

If the MGQS deactivated signal persists, contact an **OFFICIAL MOTO GUZZI DEALER**.

FACTORY SETTINGS TABLE

Riding mode	MGCM	MGCT	MGCA	MGCS
SPORT	1	1	OFF	A1
ROAD	2	2	OFF	A1
TOURING	2	3	Based on the speed	A2
RAIN	3	2	ON	A2

MGCM: LEVEL 3 IS TO BE USED IN POOR GRIP, RAIN CONDITIONS.

MGCT: LEVEL 3 IS TO BE USED IN POOR GRIP, RAIN CONDITIONS.



NOTE

THE TABLE SHOWS THE MAXIMUM INDICATIONS ON THE SETTING LEVELS OF THE VARIOUS CONTROLS. EACH RIDER MAY PERSONALISE THE LEVELS TO THEIR OWN PREFERENCE IN ACCORDANCE WITH ABILITY, RIDING STYLE AND ROAD CONDITIONS.

FOR MORE INFORMATION ON LEVEL SETTINGS, SEE THE RELATIVE PARAGRAPHS FOR EACH INDIVIDUAL FUNCTION.

KEY OF THE MGCT SYSTEM WARNING LIGHT

- **Indicator light off:** with system activated with vehicle in motion or system activated after exceeding 5 Km/h (3.1 mph) after key-on;
- **Indicator light continuously lit:** system deactivated deliberately by rider, or deactivated as a result of a malfunction;
- **Indicator light flashing slowly:** with the system active after key-on before exceeding 5 Km/h (3.1 mph) or in the case of certain malfunctions causing MGCT level to be locked ("+" and "-" buttons disabled);
- **Indicator light flashing quickly:** when MGCT system is effectively implementing traction control.

Ignition switch (02_98)

The ignition switch is on the front of the fuel tank where the steering headstock is.

The vehicle is supplied with two keys (one is the spare key).

The lights can only be switched off with the ignition switch turned to OFF.

NOTE

THE KEY IS USED IN THE IGNITION/STEERING LOCK SWITCH, THE KEYHOLE FOR THE FUEL TANK CAP, AND FOR THE SADDLE COMPARTMENT.

NOTE

THE LIGHTS COME ON AUTOMATICALLY AFTER THE ENGINE STARTS.

NOTE

KEEP THE SPARE KEY IN DIFFERENT PLACE, NOT WITH THE VEHICLE.



LOCK (1): The steering is locked. It is not possible to start the engine or switch on the lights. The key can be extracted

OFF (2): The engine and lights cannot be set to work. The key can be extracted.

ON (3): The engine can be started. The key cannot be extracted.

Locking the steering wheel (02_99)

TO PREVENT THE LOSS OF CONTROL, NEVER TURN THE KEY TO THE "LOCK" POSITION WHILE THE VEHICLE IS RUNNING.

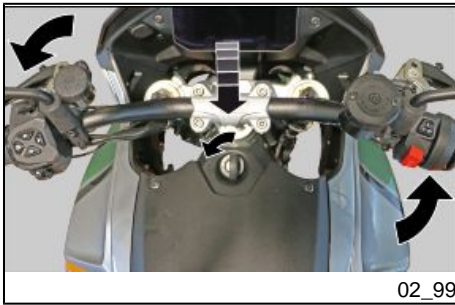
**To lock the steering:**

- Turn the handlebar fully to the left.
- Turn the key to «OFF».
- Push in the key and turn it anticlockwise (to the left), steer the handlebar slowly until the key is set to «LOCK».
- Extract the key.

**Horn button (02_100)**

Press it to activate the horn.

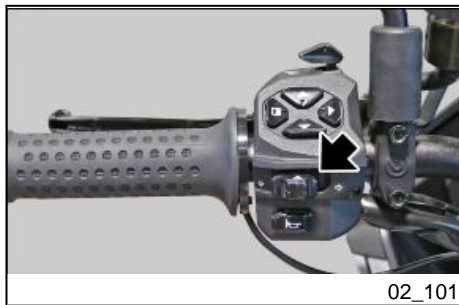

Switch direction indicators (02_101)

Move the switch to the left to indicate a left turn; move the switch to the right to indicate a right turn. Pressing the switch deactivates the turn indicator.

The turn indicators have a self-cancelling function that implements the following logic.

With the vehicle at standstill (speed = zero), the turn indicators continue flashing indefinitely.

With the vehicle in motion, the turn signals self-cancel when one of the two following conditions is met:

- After a time $(t) = 40$ sec.
- After riding 500 m (0.31 mi)

If the vehicle speed reaches zero during this period, the time and distance counts are reset and start again from zero when the vehicle starts moving once again.

Switching on the opposite side turn indicators without pressing the switch in the intermediate reset position causes both the time and distance counters to reset and recommence from zero.

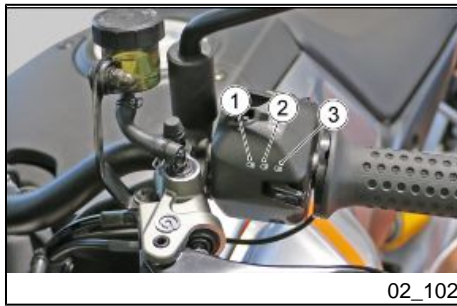

02_102

High/low beam selector (02_102)

In DRL ON mode:

- the DRL lights only are lit when the selector is left in the centre position (2).
- pressing the selector into position (1) switches on the high beam headlight
- press the selector into position (3) to flash the high beam headlamp to signal danger or an emergency.

When the low beam headlights are on (DRL OFF):

- the low beam lights only are lit when the selector is left in the centre position (2).
- pressing the selector into position (1) switches on the high beam headlight
- press the selector into position (3) to flash the high beam headlamp to signal danger or an emergency.



02_103

Passing button (02_103)

Press button (3) to flash the high beam headlamp to signal danger or an emergency.

Releasing the switch deactivates the high beam flash.

Daytime/night lights switch (02_104, 02_105)

This button allows to select the use mode of the daytime running lights (DRL), night lights (low / high beams) and the activation of the fog lights (where provided).

- Press the button briefly to cycle through the modes available (daytime/night-time lights).
- A long press of the button will activate the fog lights regardless of the lighting mode active.
- A further long press will deactivate the fog lights.

NOTE

IF THE "HEADLAMP MODE" FUNCTION (SEE PARAGRAPH "ADVANCED FUNCTIONS") IS SET TO "AUTO" (AUTOMATIC), THE TWILIGHT SENSOR IS ALSO USED TO SWITCH THE LOW BEAM HEADLIGHTS ON AUTOMATICALLY IN LOW LIGHT CONDITIONS.

IF THE "HEADLAMP MODE" FUNCTION IS SET TO "EMERGENCY", THE DAY-TIME RUNNING LIGHTS (DRL) ARE DISABLED AND THE LOW BEAM HEADLIGHTS ONLY REMAIN PERMANENTLY LIT.

NOTE

THE FOG LIGHTS WILL BE DEACTIVATED WITH EACH KEY OFF/ON.

THE LOW/HIGH BEAM LIGHTS ARE ONLY ON WHEN THE ENGINE IS RUNNING.

NOTE

WHEN THE LOW BEAM HEADLIGHTS ARE ON (A), THE BRIGHTNESS OF THE DRL LIGHTS (B) IS DIMMED.



02_104

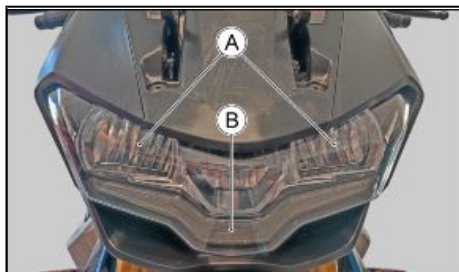

02_105



WARNING

Flashing of the fog lights icon on the digital display indicates a problem with the front light cluster. Contact an OFFICIAL MOTO GUZZI DEALER as soon as possible.

Heated handgrip control (02_106, 02_107)

(if applicable)

The activation, deactivation and heat level of the heated hand grips is performed with the control button.

The page dedicated to setting the heated grips can be viewed by scrolling through the pages in the space dedicated to the trip log.

By briefly pressing the MODE UP button it is possible to activate the heating and subsequently with further presses to increase the heat intensity level.

By briefly pressing the MODE DOWN button it is possible to lower the intensity level and subsequently deactivate the system.

NOTE

HEATING OF THE HAND GRIPS, REGARDLESS OF THE INTENSITY LEVEL CHOSEN, ONLY OCCURS WITH THE ENGINE STARTED AND OVER 2000 rpm

NOTE

THE HEATED GRIPS ARE OFF WITH EACH KEY OFF-ON.

NOTE

THE FLASHING SYMBOL INDICATES THE MALFUNCTION OF A GRIP.



Heated saddle control (where provided)

The heated saddle is switched on, off and the heat level is set using the control buttons.

The page dedicated to setting the heated saddle can be viewed by scrolling through the pages in the space dedicated to the trip log.

By briefly pressing the MODE UP button it is possible to activate the heating and subsequently with further presses to increase the heat intensity level.

By briefly pressing the MODE DOWN button it is possible to lower the intensity level and subsequently deactivate the system.

NOTE

HEATING OF THE SADDLE, REGARDLESS OF THE INTENSITY LEVEL CHOSEN, ONLY OCCURS WITH THE ENGINE STARTED AND OVER 2000 rpm

NOTE

EACH OFF-ON KEY SWITCHES THE SADDLE HEATING OFF.

NOTE

THE FLASHING SYMBOL INDICATES THE MALFUNCTION OF THE HEATING SYSTEM.



Start-up button (02_108)

By pressing the button on the right side handlebar, the starter motor spins the engine.

The following conditions are necessary to permit engine start:

- If the vehicle is in neutral with the side stand extended: Press the starter button on the right side handlebar.
- If the vehicle has any gear is engaged and the stand is closed: Pull the clutch lever and at the same time press the starter button on the right side handlebar.

Engine stop switch (02_109)

CAUTION



DO NOT OPERATE THE ENGINE STOP SWITCH WHILE RIDING THE VEHICLE.



It acts as a safety or emergency switch.

Press and hold the ignition switch in the "KEY ON" position to start the engine; press the switch to set it to "KEY OFF" to stop the engine.

NOTE

WITH ENGINE OFF AND THE IGNITION SWITCH SET TO «ON» THE BATTERY MAY DISCHARGE.

Button Cruise Control (02_110, 02_111, 02_112, 02_113)

CAUTION

ALWAYS SWITCH OFF THE SYSTEM (SWITCHING FROM ON TO OFF) BEFORE CHANGING THE RIDING MODE.



02_110

Cruise control is an electronic system that keeps the vehicle at a constant speed selected by the rider.

Push and hold (more than 1 second) the cruise control selector to the left switch the system on (OFF -> ON). The relative indicator on the dashboard instrument panel flashes to confirm that the system is on.

Going from OFF to ON is also possible with the engine off, as long as the engine stop switch is on RUN.

NOTE

IF THERE IS AN ANTI-THEFT SYSTEM, IT SHOULD BE UNLOCKED TO ALLOW THE SYSTEM TO BE ACTIVATED.



02_111

The system can be used in certain ranges of speeds for the gears from the third to the sixth, even during deceleration and with the throttle grip released.

The maximum and minimum settable speed values depend on the gear currently selected

Once at the required speed, the cruise control system may be activated by the rider (switched to SET state) by pushing the cruise control selector briefly (for less than 1 second) to the left, provided that the following conditions are met:

- The engaged gear cannot be less than the third and even in neutral;
- The brakes should not be operated;
- The clutch must not be operated;
- The speed conforms to the limit established for each gear

The indicator lamp on the instrument cluster lights continuously to indicate that the system is active.

The rider may now release the throttle grip, as the system will automatically maintain the set speed.

It is possible to increase or decrease the cruising speed by a short press (less than 1 second) of the cruise control switch up or down (increase / decrease the speed of 2 km/h (1.24 mph)) or via a long press (from 1 to 20 seconds) up or down (increase / decrease in the constant speed). The throttle may be used to increase speed tempo-



rarily by up to 30 km / h (18.64 mph) for the third, fourth and fifth gear and 40 km / h (24.85 mph) for the sixth gear with respect to the selected speed without turning off the system (e.g. passing). If the increase in speed exceeds 30 km/h (18.64 mph) for the third, fourth and fifth gear and 40 km/h (24.85 mph) for the sixth gear, it will cause a system deactivation (change from SET to ON, flashing light). Released the throttle grip, the motorcycle will return to the selected cruising speed.

The system is deactivated (change from SET to ON status) if any of the following conditions:

- By operating the clutch;
- Operating the front/rear brake;
- Inserting a lower gear than 3rd or shift into neutral;
- By briefly moving the selector to the left;
- If the engine rpm limiter is activated;
- If the tracking control is activated;
- If climbs or particularly steep descents appear;
- Turning the throttle grip in the direction of contrary rotation

The system can be activated any time observing as usual the previously described conditions and keeping the selector pressed upward (for more than 1 second) if you want to reconfirm the last cruise speed used or by briefly moving the selector to the left to set a new cruising speed.

The system turns off completely (change from SET to the OFF state), then the stored speed is lost and the instrument cluster light goes off, if any of the following conditions are present:

- Keeping the cruise control selector moved to the left (for more than 1 second);
- Run-off interrupter activated;
- Engine stop (Key-OFF);
- Failure, malfunction of a component involved in controlling the speed (tone wheels sensors, control units, etc.)

CAUTION

WHEN ENTERING THE ADJUSTMENT MODE OF THE CRUISE CONTROL, THE QUICK SHIFT SYSTEM IS DISABLED.

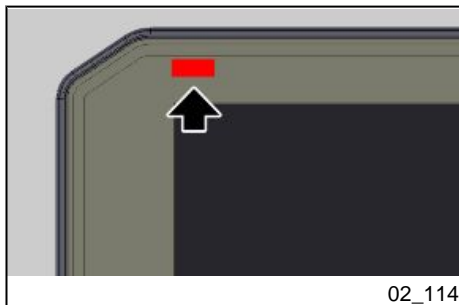

02_114

Immobilizer system operation (02_114, 02_115, 02_116)

For enhanced theft protection, the vehicle is equipped with an electronic immobilizer system that is activated automatically when the ignition key is removed.

Keep the second key in a safe place since it is not possible to make a copy if it gets lost. This would imply replacing numerous parts of the vehicle (besides the locks).

Each key in the grip has an electronic device - transponder - which modulates the radio frequency signal emitted by a special aerial inside the switch when the vehicle is started.

The modulated signal is the "password" by which the appropriate central unit recognises the key and only after this occurs, it allows the engine start-up.

CAUTION

THE IMMOBILIZER SYSTEM CAN MEMORISE UP TO FOUR KEYS.

DATA STORAGE OPERATION CAN ONLY BE PERFORMED AT A DEALER.

DATA STORAGE PROCEDURE CANCELS THE EXISTING CODES. THEREFORE, IF A CUSTOMER WANTS TO PROGRAM SOME NEW KEYS, S/HE SHOULD GO TO THE DEALER TAKING ALL THE KEYS S/HE WANTS TO ENABLE.



In the event the instrument panel detects a fault with the immobilizer system when the key is connected, you will need to enter the user code to start the motorcycle. At the same time the indicator light appears on the instrument panel, the general red warning light will come on.



Once the code has been correctly entered, the identified error will be displayed on the screen. It is then possible to start the motorcycle so you can go immediately to an Authorised **Moto Guzzi** Dealer.

CAUTION

PRESSING OR MOVING ANY CONTROL ON THE LEFT SWITCH CLUSTER, IT IS POSSIBLE TO REMOVE THE ERROR NOTIFICATION SCREEN, BUT THE SCREEN WILL BE VISIBLE AGAIN AFTER ABOUT 10 SECONDS.

Opening the saddle (02_117, 02_118, 02_119, 02_120, 02_121)

- Rest the vehicle on its stand.
- Insert the key in the saddle lock located on the left-hand side fairing.
- Turn the key clockwise to release the passenger saddle from the lock.



02_117

- Lift the front part of the passenger saddle and bring it toward the rear of the vehicle to remove it.
- Now it is possible to access the storage compartment of the vehicle.



02_118

- Lift the rear part of the rider saddle, bring it toward the rear of the vehicle to release it from the relative supports and then remove it from the vehicle.
- Once the driver and passenger saddles are removed, you will have access to the vehicle's battery.



02_119



Refitting the saddles:

- Move the rider saddle rider in its position, taking care to insert the central fastener and the two front fasteners in the relative seats.



- Insert the rear fastener of the passenger saddle in its support on the vehicle.
- Keeping the saddle in position, press downward the front part to engage the lock.

CAUTION

BEFORE LOWERING AND LOCKING THE SADDLE, MAKE SURE THAT THE IGNITION KEY HAS NOT BEEN FORGOTTEN IN AN UNSUITABLE POSITION UNDER THE SADDLE.



BEFORE RIDING, MAKE SURE THAT THE SADDLE IS CORRECTLY LOCKED.



02_122

USB Port (02_122, 02_123)

The vehicle is equipped with a USB port, located in the storage compartment under the passenger saddle.

To use it, remove the protection cap from the port. To prevent damage to the port, put the protective cap whenever the port is not in use.



IF A USB DEVICE IS CONNECTED, ENSURE THE CORRECT POSITIONING OF THE CABLE TO AVOID THAT IT WILL BE SMASHED.

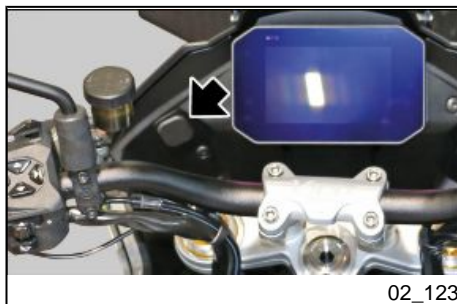

02_123

Additional USB port (if provided)

The additional USB port (if installed) is located next to the dashboard on the left side of the top fairing.



TO PREVENT WATER AND/OR HUMIDITY FROM DAMAGING THE USB PORT, DO NOT CONNECT ANY DEVICES IN CASE OF RAIN.



IF A USB DEVICE IS CONNECTED, ENSURE THE CORRECT POSITIONING OF THE CABLE TO AVOID THAT IT WILL BE SMASHED.

The USB ports are activated when the key is turned to the "ON" position.

WARNING

PROLONGED USE OF THE USB PORT MAY PARTIALLY DRAIN THE BATTERY.

USB PORT

Output voltage:	(5.00+/-0.25) dc
Charge current	1A Max

Identification (02_124, 02_125)

Write down the chassis and engine number in the specific space in this booklet. The chassis number is handy when purchasing spare parts.

CAUTION



THE MODIFICATION OF THE IDENTIFICATION CODES IS A SERIOUS PUNISHABLE CRIME. HOWEVER, THE LIMITED WARRANTY FOR NEW VEHICLES WILL BE VOID IF THE VEHICLE IDENTIFICATION NUMBER (VIN) HAS BEEN MODIFIED OR NOT PROMPTLY DETERMINED.

FRAME NUMBER

The chassis number is stamped on the RH side of the headstock.

Chassis No.





02_125

ENGINE NUMBER

The engine number is stamped on the left side of the crankcase, under the cylinder.

Engine No.



02_126

Adjusting the windscreen (02_126)

The windscreen height can be adjusted electronically by selecting "WINDSCREEN REGULATION" using the "MODE SET" button on the left-hand switch. The height can then be adjusted using the MODE UP and MODE DOWN buttons on the left-hand switch.

V100 Mandello - V100 Mandello S



Chap. 03
Use

Checks (03_01)

CAUTION

BEFORE DEPARTURE, ALWAYS CARRY OUT A PRELIMINARY CHECK OF THE VEHICLE, FOR CORRECT AND SAFE OPERATION. FAILURE TO DO SO MAY CAUSE SEVERE PERSONAL INJURY OR VEHICLE DAMAGE. DO NOT HESITATE TO CONTACT AN Official Moto Guzzi Dealer IF YOU DO NOT UNDERSTAND HOW SOME CONTROLS WORK OR IF MALFUNCTIONING IS DETECTED OR SUSPECTED. CHECKS DO NOT TAKE LONG AND RESULT IN SIGNIFICANTLY ENHANCED SAFETY.



This vehicle has been programmed to indicate in real time any operation failure stored in the electronic control unit memory.

Every time the ignition switch is turned to "ON", the alarm LED warning lights turn on for about three seconds on the dashboard.

PRE-RIDE CHECKS

Front and rear disc brake

Check for proper operation. Check brake lever empty travel and brake fluid level. Check for leaks. Check brake pads for wear. If necessary top-up with brake fluid.

Throttle grip	Check that the rotation is smooth in both directions and that there is no jamming.
Engine oil	Check and/or top-up as required.
Wheels/ tyres	<p>Check that tyres are in good conditions. Check inflation pressure, tyre wear and potential damage.</p> <p>Remove any possible strange body that might be stuck in the tread design.</p>
Brake levers	<p>Check they function smoothly.</p> <p>Lubricate the joints and adjust the travel if necessary.</p>
Clutch lever	Check correct operation and empty travel. Lubricate the joints if necessary.
Steering	Check that the rotation is uniform, smooth and there are no signs of clearance or slackness.
Side stand	Check that it slides smoothly and that it snaps back to its rest position upon spring tension. Lubricate couplings and joints if necessary.
Clamping elements	<p>Check that the clamping elements are not loose.</p> <p>Adjust or tighten them as required.</p>
Fuel tank	Check level and refill if necessary.

Check the circuit for leaks or obstructions.

Check that the tank cap closes correctly.

Engine stop switch (ON - OFF)	Check function.
Lights, warning lights, horn and electrical devices	Check function of horn and lights.
Tone wheel	Check the front tone wheel for cleanliness and damage.

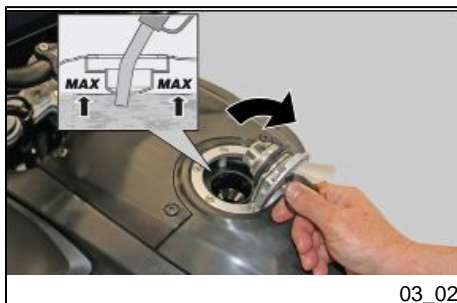

Refuelling (03_02, 03_03)

To refuel:

- Lift the cover (1).
- Introduce the key (2) in the fuel tank cap lock
- Turn the key clockwise, pull and open the fuel filler cap (3).

CAUTION



ALWAYS USE PETROL WITH A MAXIMUM OF 10% BIOETHANOL CONTENT (E10).

DO NOT USE PETROL WITH AN ETHANOL CONTENT HIGHER THAN 10%; THIS USE COULD DAMAGE THE FUEL SYSTEM COMPONENTS AND/OR COMPROMISE ENGINE PERFORMANCE.

Characteristic

Fuel tank capacity (including reserve)

17 l (3.74 UK gal; 4.49 US gal)

Fuel tank reserve capacity

3.5 +/- 0.5 l (0.77 +/- 0.11 UK gal; 0.92 +/- 0.13 US gal)

NOTE

NEVER COMPLETELY TOP-UP THE RESERVOIR; THE MAXIMUM FUEL LEVEL MUST REMAIN BELOW THE LOWER EDGE OF THE SUMP (SEE FIGURE).

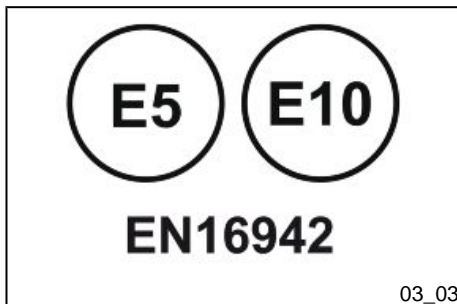

The EN16942 European standard requires the identification of the compatibility of the vehicles with the fuel type by means of a graphic symbol for consumer information. The symbols listed below facilitate the recognition of the correct fuel type to be used on your vehicle. Before refuelling, check the symbols located near the filler neck and compare them with the symbol shown on the filling pump.

E5: unleaded gasoline with 5% maximum Ethanol percent.

E10: unleaded gasoline with 10% maximum Ethanol percent.

The label on each pump dispenser shows only one value; if for example it shows E5 it means that the petrol supplied is unleaded, with 5% ethanol.

However, the label on the vehicle may show several values. If, for example, it shows both E5 and E10 values, it means that the vehicle is compatible with gasoline containing maximum 10% Ethanol and thus the Customer may refuel either from a E5 dispenser or from a E10 dispenser (but not from an E85 dispenser).

- Refill.

CAUTION



**DO NOT ADD ADDITIVES OR ANY OTHER SUBSTANCES TO THE FUEL.
WHEN USING A FUNNEL, ENSURE THAT IT IS PERFECTLY CLEAN.**



**DURING REFUELLING AVOID FUEL LEAKAGES, WHICH MAY CAUSE DAMAGE
TO THINGS OR PERSONS AND FIRE HAZARD.**

**DURING REFUELLING, AVOID THE USE OF ELECTRIC DEVICES AND/OR MO-
BILE PHONES, BECAUSE FUEL VAPOURS MAY CAUSE DAMAGE TO OBJECTS
AND/OR PERSONAL INJURIES.**

After refuelling:

- The cap can only be closed if the key (2) is inserted.
- Once the key (2) is inserted, press the cap to close it again.
- Remove the key (2).
- Close the cover (1).



MAKE SURE THE CAP IS TIGHTLY CLOSED.

Rear shock absorbers adjustment (03_04, 03_05, 03_06)

The shock absorber, in both "V100 Mandello" and "V100 Mandello S" versions, has an external adjuster (1) for adjusting the spring pre-load.

NOTE

IT IS POSSIBLE TO VARY THE PRE-LOAD OF THE SHOCK ABSORBER DEPENDING ON THE LOAD ON THE VEHICLE (PASSENGER OR HEAVY LOAD).

CAUTION

DO NOT FORCE THE ROTATION OF THE ADJUSTMENT SCREW BEYOND THE LIMIT STOP IN BOTH DIRECTIONS, IN ORDER TO PREVENT ANY DAMAGE.



On the upper part of the shock absorber, only for "V100 Mandello", there is an adjuster (2) to adjust the rebound hydraulic braking. Instead, the shock absorber settings on "V100 Mandello S" are electronically adjusted and can be adjusted via the instrument panel. For more information, refer to "ADVANCED FUNCTIONS" in the "VEHICLE" chapter.

CAUTION

DO NOT FORCE THE ROTATION OF THE ADJUSTMENT SCREW BEYOND THE LIMIT STOP IN BOTH DIRECTIONS, IN ORDER TO PREVENT ANY DAMAGE.

Spring pre-load

By adjusting the spring pre-load, the seat of the spring itself is moved. Carrying out the adjustment, you can decrease or increase the stiffness of the spring and therefore lower or raise the height of the rear of the vehicle. The spring pre-load is essential for the function performed by the rear shock absorbers. If the spring pre-load is not adjusted correctly, no other adjustment will be effective to obtain good shock absorber performance.

Rebound braking

Rebound braking controls the energy absorption when the shock absorber is in the rebound phase. In other words, rebound braking adjusts the speed at which the shock absorber returns to the normal position after having been compressed.



SET SPRING PRE-LOADING AND SHOCK ABSORBER REBOUND DAMPING ACCORDING TO THE VEHICLE USE CONDITIONS.

IF THE SPRING PRE-LOADING IS INCREASED, IT IS NECESSARY TO INCREASE THE REBOUND DAMPING ACCORDINGLY TO AVOID SUDDEN JERKS WHEN RIDING.

CAUTION

ALWAYS OBSERVE THE RECOMMENDED ADJUSTMENT RANGE.

FOR THE CORRECT SETTING PARAMETERS, READ THE PARAGRAPH "SETTING THE REAR SHOCK ABSORBERS" CAREFULLY.

IF NECESSARY, CONTACT AN Official Moto Guzzi Dealer.

Rear shock absorbers setting (03_07, 03_08, 03_09)

V 100 MANDELLO

Spring pre-load adjustment

To adjust the spring pre-load, turn the adjuster knob (1) clockwise to increase the pre-load or counterclockwise to decrease it.

CAUTION

DO NOT FORCE THE ROTATION OF THE ADJUSTMENT SCREW BEYOND THE LIMIT STOP IN BOTH DIRECTIONS, IN ORDER TO PREVENT ANY DAMAGE.

NOTE

AS THE PRE-LOAD INCREASES, THE SPRING LENGTH WILL DECREASE, AND VICE VERSA IF THE PRE-LOAD DECREASES, THE SPRING LENGTH WILL INCREASE.

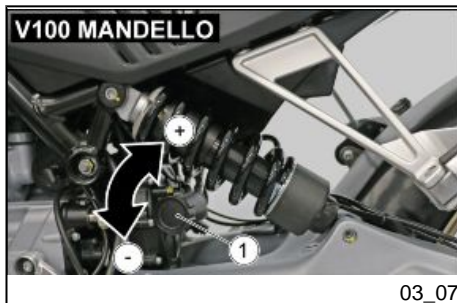

Rebound braking adjustment

To adjust the rebound (return) braking, use a flat-head screwdriver to turn the adjuster (2) located at the top of the shock absorber.

Turn the adjuster clockwise to increase braking, or counter-clockwise to decrease braking.

CAUTION

DO NOT FORCE THE ROTATION OF THE ADJUSTMENT SCREW BEYOND THE LIMIT STOP IN BOTH DIRECTIONS, IN ORDER TO PREVENT ANY DAMAGE.

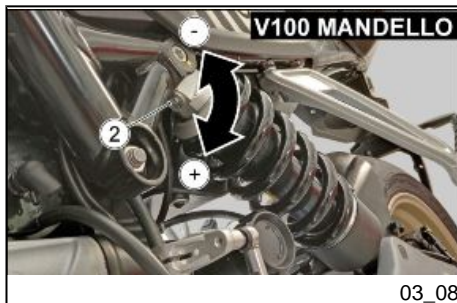

Follow the instructions in the tables below for the optimal setting of the vehicle according to the conditions of use.

RECOMMENDED SETTING V100 MANDELLO

TYPE OF ADJUSTMENT	RIDER ONLY	RIDER + BAGS AND TOP CASE OR RIDER + PASSENGER	RIDER + PASSENGER + BAGS AND TOP CASE
PRE-LOAD (KNOB) - FROM COMPLETELY OPEN (**) CLOSE (*)	1 click	22 clicks	26 clicks
HYDRAULIC BRAKING (ADJUSTER) - FROM COMPLETELY CLOSED (*) OPEN (**)	2 turns	1 turn	1 turn

(*) = clockwise

(**) = anticlockwise

V 100 MANDELLO S

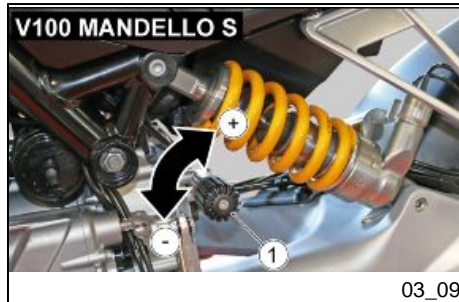

Spring pre-load adjustment

To adjust the spring pre-load, turn the adjuster knob (1) clockwise to increase the pre-load or counterclockwise to decrease it.

CAUTION

DO NOT FORCE THE ROTATION OF THE ADJUSTMENT SCREW BEYOND THE LIMIT STOP IN BOTH DIRECTIONS, IN ORDER TO PREVENT ANY DAMAGE.

NOTE

AS THE PRE-LOAD INCREASES, THE SPRING LENGTH WILL DECREASE, AND VICE VERSA IF THE PRE-LOAD DECREASES, THE SPRING LENGTH WILL INCREASE.

RECOMMENDED SETTING V100 MANDELLO S

TYPE OF ADJUSTMENT	RIDER ONLY	RIDER + BAGS AND TOP CASE OR RIDER + PASSENGER	RIDER + PASSENGER + BAGS AND TOP CASE
PRE-LOAD (KNOB) - FROM COMPLETELY OPEN (**) CLOSE (*)	4 turns	12 turns	16 turns

"SPORT" setting:

- MGCS mode: A1 - Dynamic

"ROAD" Setting:

- MGCS mode: A2 - Comfort

"TOURING" Setting:

- MGCS mode: A1 - Dynamic

"RAIN" setting:

- MGCS mode: A2 - Comfort

The pre-load of the rear shock absorber depends on the load on the vehicle, NOT on the "Riding Mode" used. Therefore, always refer to the "RECOMMENDED settings" table above for pre-load adjustment.



ALL MODES CAN BE EDITED BY THE USER AND IT IS ALWAYS POSSIBLE TO RETURN EACH MODE TO THE FACTORY SETTINGS, AS EXPLAINED IN THE "ADVANCED FUNCTIONS" PARAGRAPH.

IF YOU WANT TO CHANGE THE FACTORY SETTINGS, TEST THE VEHICLE REPEATEDLY UNTIL THE OPTIMUM ADJUSTMENT IS OBTAINED.

IF NECESSARY, CONTACT AN Official Moto Guzzi Dealer.



03_10

Front fork adjustment (03_10, 03_11, 03_12, 03_13, 03_14, 03_15)

Operating the front brake lever, press the handlebar repeatedly to send the fork fully down. The shock absorber should compress and extend smoothly with no signs of oil leakage on the stanchions.

Check the tightening of all the elements and the correct operation of the front and rear suspension joints.

CAUTION

TO HAVE THE FRONT FORK OIL AND OIL SEALS REPLACED, CONTACT AN Official Moto Guzzi Dealer.

V 100 MANDELLO



03_11

The front suspension consists of a hydraulic fork connected to the headstock by means of two plates.

The right stem of the fork has an upper nut (2) for adjusting the spring pre-load and an upper adjustment screw (1) for adjusting the hydraulic braking in rebound.



DO NOT FORCE THE ROTATION OF THE ADJUSTMENT SCREW BEYOND THE LIMIT STOP IN BOTH DIRECTIONS, IN ORDER TO PREVENT ANY DAMAGE.

WHEN SPRING PRE-LOAD IS INCREASED, REBOUND DAMPING MUST ALSO BE INCREASED TO PREVENT EXCESSIVE SUSPENSION KICKBACK WHEN RIDING.

The standard front fork setting is adjusted to suit most high and low speed riding conditions, whether the vehicle is partially or fully loaded.

However, the setting can be modified for specific needs according to vehicle use.

CAUTION

FOR THE CORRECT SETTING PARAMETERS, READ THE PARAGRAPH "SETTING THE FRONT FORK" CAREFULLY.

IF NECESSARY, CONTACT AN Official Moto Guzzi Dealer.

V 100 MANDELLO S

- The spring pre-load is adjusted by the manufacturer to suit any riding type; therefore, even if possible, it is strongly advised not to change the adjustment.





- To adjust the spring pre-load, it is necessary to disconnect the connector (1) from the stem plug, so as not to twist the wiring harness during the adjustment operations.



TO AVOID DAMAGING THE CONNECTOR, PRESS THE TAB (2) ON THE INDICATED POINT AND THEN CAREFULLY REMOVE THE CONNECTOR.



PAY SPECIFIC ATTENTION WHEN DISCONNECTING THE CONNECTORS, TO AVOID DAMAGING THEM, WHICH WOULD COMPROMISE THE OPERATION OF THE VEHICLE.

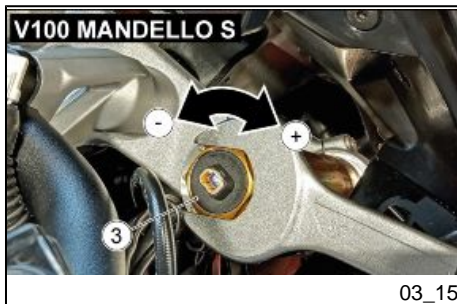

- Using a spanner, turn the adjusting nut (3) clockwise to increase the pre-load or anti-clockwise to decrease it.
- Repeat the adjustment operations for the second stem, taking care to adjust both stems equally.



SET THE SPRING PRE-LOADING AND THE EXTENSION HYDRAULIC BRAKING OF THE FRONT FORK ACCORDING TO THE VEHICLE USE CONDITIONS.

BY INCREASING THE SPRING PRE-LOAD, THE CONTROL PARAMETERS OF THE FRONT FORK MUST BE ADJUSTED (BY INCREASING THEIR VALUES) TO AVOID UNEXPECTED JOLTS WHILE DRIVING.

- The "V 100 Mandello S" fork adjustments are performed electronically; these settings can be adjusted via the instrument panel. For more information, refer to "ADVANCED FUNCTIONS" in the "VEHICLE" chapter.

Front fork setting (03_16, 03_17, 03_18, 03_19)

V 100 MANDELLO



TO COUNT THE NUMBER OF CLICKS AND/OR REVOLUTIONS OF ADJUSTMENT SETTINGS ALWAYS START FROM THE MOST RIGID SETTING (WHOLE CLOCKWISE ROTATION OF THE SETTING).

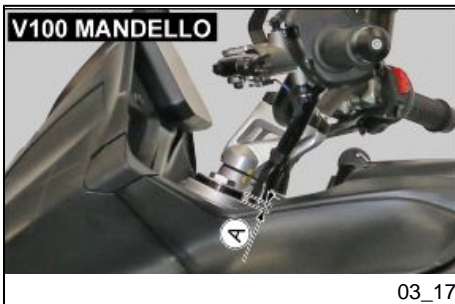

03_17

RECOMMENDED SETTING

TYPE OF ADJUSTMENT	RIDER ONLY	RIDER + BAGS AND TOP CASE OR RIDER + PASSENGER	RIDER + PASSENGER + BAGS AND TOP CASE
PRE-LOAD (NUT) - FROM COMPLETELY OPEN (**) CLOSE (*)	6 turns	6 turns	6 turns
HYDRAULIC BRAKING (ADJUSTER) - FROM COMPLETELY CLOSED (*) OPEN (**)	6 clicks	6 clicks	6 clicks
STANCHION PROTRUSION (A) (***) FROM TOP YOKE (EXCLUDING COVER)	1 notch (5 mm - 0.20 in)	1 notch (5 mm - 0.20 in)	1 notch (5 mm - 0.20 in)

(*) - Clockwise

(**) - Anticlockwise

(***) - this type of adjustment may only be made by an **Authorised Moto Guzzi Dealer**.

V 100 MANDELLO S

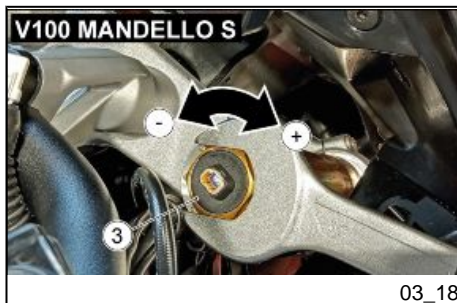

The factory settings of the MGCS system are as follows:

"SPORT" setting:

- Spring pre-load (3): From fully open, 8 turns clockwise
- MGCS mode: A1 - Dynamic
- Stanchion protrusion (A) (**): 1 notch (4 mm - 0.16 in)

"ROAD" Setting:

- Spring pre-load (3): From fully open, 8 turns clockwise
- MGCS mode: A2 - Comfort
- Stanchion protrusion (A) (**): 1 notch (4 mm - 0.16 in)

"TOURING" Setting:

- Spring pre-load (3): From fully open, 8 turns clockwise
- MGCS mode: A1 - Dynamic
- Stanchion protrusion (A) (**): 1 notch (4 mm - 0.16 in)

"RAIN" setting:

- Spring pre-load (3): From fully open, 8 turns clockwise
- MGCS mode: A2 - Comfort
- Stanchion protrusion (A) (**): 1 notch (4 mm - 0.16 in)

(**) - this type of adjustment may only be made by an **Authorised Moto Guzzi Dealer**.



ALL MODES CAN BE EDITED BY THE USER AND IT IS ALWAYS POSSIBLE TO RETURN EACH MODE TO THE FACTORY SETTINGS, AS EXPLAINED IN THE "ADVANCED FUNCTIONS" PARAGRAPH.

IF YOU WANT TO CHANGE THE FACTORY SETTINGS, TEST THE VEHICLE REPEATEDLY UNTIL THE OPTIMUM ADJUSTMENT IS OBTAINED.

IF NECESSARY, CONTACT AN Official Moto Guzzi Dealer.

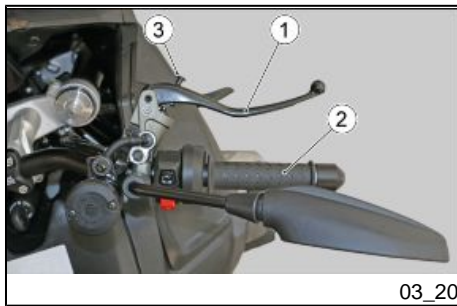

03_20

Adjusting the front brake lever (03_20)

It is possible to adjust the distance between the end of the lever (1) and the grip (2), turning the adjuster (3).

- Push the control lever (1) forwards and turn the adjuster (3) until the lever (1) is at the desired distance.
- Turning the adjuster clockwise moves the lever (1) away from the handle (2).

CAUTION

IF THE FRONT BRAKE LEVER MUST BE REMOVED, CHECKED AND CHANGED BY AN Official Moto Guzzi Dealership



03_21

Rear brake pedal adjustment (03_21)

The control levers are positioned ergonomically when the vehicle is being assembled.

if necessary, it is possible to customise the position of the levers.

- Rest the vehicle on its stand.
- Partially undo the screw (1).
- Turn the cam (2) finding the best position for the pedal (3).
- Tighten the screw (1) and check the cam is stable in position.

CAUTION

TO ADJUST THE BRAKE LEVER CLEARANCE, CONTACT AN Official Moto Guzzi Dealer.

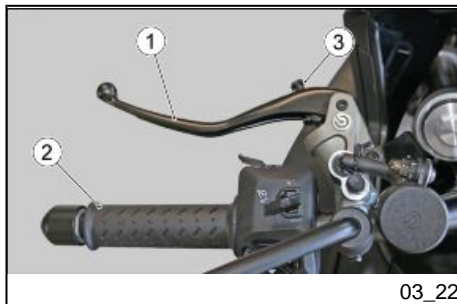

Clutch lever adjustment (03_22)

It is possible to adjust the distance between the end of the lever (1) and the grip (2), turning the adjuster (3).

- Push the control lever (1) forwards and turn the adjuster (3) until the lever (1) is at the desired distance.
- Turning the adjuster clockwise moves the lever (1) away from the handle (2).

CAUTION

CONTACT AN Official Moto Guzzi dealer TO REMOVE AND REPLACE THE CLUTCH LEVER



IN THE EVENT FAULTS AND/OR MALFUNCTIONS IN THE CLUTCH CONTROL, CONTACT AN Official Moto Guzzi dealer

Running in

Running in is essential to ensure the durability of the vehicle. During the first 1500 Km (932 mi), observe the following rules to ensure the reliability and performance of the vehicle throughout its lifetime:

- Avoid full throttle starts and hard acceleration;
- Avoid exceeding 4,500 rpm;
- Avoid hard or prolonged braking;
- Do not ride for prolonged periods at sustained high speed; preferably ride the motorcycle on varied routes with frequent, gentle acceleration and deceleration;
- Ride prudently to gradually gain familiarity with the motorcycle, testing progressively higher throttle apertures only as you gain confidence

CAUTION

THE FULL PERFORMANCE OF THE VEHICLE IS ONLY AVAILABLE AFTER THE SERVICE AT THE END OF THE RUNNING IN PERIOD.



TO PREVENT THE RISK OF INJURY TO YOURSELF OR OTHERS AND/OR DAMAGE TO THE VEHICLE, TAKE YOUR MOTORCYCLE TO AN AUTHORISED Moto Guzzi DEALER AT THE SPECIFIED MILEAGE INTERVALS TO HAVE THE CHECKS LISTED IN THE "SCHEDULED MAINTENANCE TABLE" CARRIED OUT.

Starting up the engine (03_23, 03_24, 03_25)

This vehicle is extremely powerful and must be used carefully and driven with caution and respect for its power and potential.

Do not place objects inside the top fairing (between the handlebar and the instrument cluster), as this may impede the movements of the handlebar and obstruct visibility of the instruments.



EXHAUST FUMES CONTAIN CARBON MONOXIDE, AN EXTREMELY HARMFUL SUBSTANCE IF INHALED.

NEVER START THE ENGINE IN A CLOSED OR INSUFFICIENTLY VENTILATED SPACE.



FAILURE TO OBSERVE THIS WARNING COULD LEAD TO UNCONSCIOUSNESS AND EVEN DEATH DUE TO SUFFOCATION.

CAUTION

WITH THE SIDE STAND LOWERED, THE ENGINE MAY ONLY BE STARTED WITH THE GEARBOX IN NEUTRAL. IF YOU ATTEMPT TO ENGAGE THE GEAR, THE ENGINE WILL STOP.

WITH THE SIDE STAND RETRACTED, THE ENGINE MAY BE STARTED WITH THE GEARBOX IN NEUTRAL OR WITH THE GEAR ENGAGED AND THE CLUTCH LEVER OPERATED.

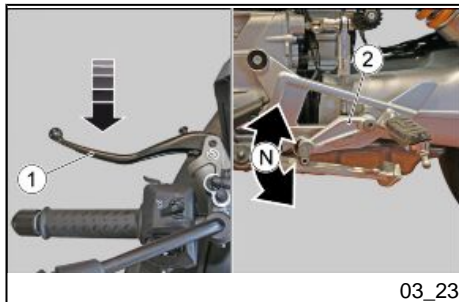

03_23

- Get on the motorcycle, assuming the correct driving posture.
- Make sure that the side stand has been fully retracted.
- Operate the front or rear brake (or both).
- Operate the clutch lever (1) and make sure that the transmission (2) is in neutral.



03_24

- Turn the ignition key (3) to "ON".

At this stage:

- The starting screen will be displayed on the digital display for about 2 seconds and then the screen with the standard parameters will appear.
- All the indicator lights on the dashboard will come on for about 2 seconds.
- Press the starter button (4) once only.
- With the engine operating normally, all instantaneous parameters will be visible in the digital display.



IF THE LOW FUEL WARNING LIGHT ON THE DASHBOARD TURNS ON, REFUEL THE VEHICLE AT ONCE.



INTENSE USE/ON THE TRACK IN RESERVE CAN DAMAGE THE ENGINE.



ON NEW VEHICLES, THE SHIFT LIGHT THRESHOLD IS SET TO 5200 RPM. RAISE THE THRESHOLD GRADUALLY UNTIL YOU HAVE BECOME FAMILIAR WITH THE VEHICLE AND THE RUN-IN HAS BEEN COMPLETED.



AFTER A FEW SECONDS FROM THE ENGINE START-UP, THE START-UP BUTTON ASSUMES THE RIDING MODE CHANGE FUNCTION.



IF THE GENERAL WARNING INDICATOR LIGHT ON THE DASHBOARD COMES ON, IT MEANS THAT THE CONTROL UNIT HAS ENCOUNTERED A FAULT, THEREFORE IT IS NECESSARY TO CONTACT AN Authorised Moto Guzzi Dealer.



DO NOT SET OFF SUDDENLY WHEN THE ENGINE IS COLD. RIDE AT LOW SPEED FOR SEVERAL KILOMETRES. THIS WILL ALLOW THE ENGINE TO WARM UP AND REDUCE POLLUTING EMISSIONS AND FUEL CONSUMPTION.

Moving off / riding (03_26, 03_27, 03_28)

CAUTION

THE ECU INSTALLED ON THIS MOTORCYCLE COMPENSATES FOR INCREASED ELECTRIC POWER CONSUMPTION BY TEMPORARILY RAISING THE IDLE SPEED; VARIATIONS IN ENGINE SPEED WITHIN THIS RANGE ARE THEREFORE NORMAL.



IF THE LOW FUEL WARNING LIGHT ON THE DASHBOARD TURNS ON, REFUEL THE VEHICLE AT ONCE.

WARNING

IF THE MOTORCYCLE TURNS OFF ACCIDENTALLY THE ECU ALLOWS A RESTART WITHIN THE NEXT 5 SECONDS. ONCE THIS PERIOD OF TIME HAS PASSED THE ECU WILL PREVENT STARTING FOR ANOTHER 3 SECONDS AND ONLY THEN WILL IT BE POSSIBLE TO START THE MOTORCYCLE.

CAUTION

WHEN TRAVELLING WITHOUT PASSENGERS, MAKE SURE THE PASSENGER FOOTRESTS ARE FOLDED UP.

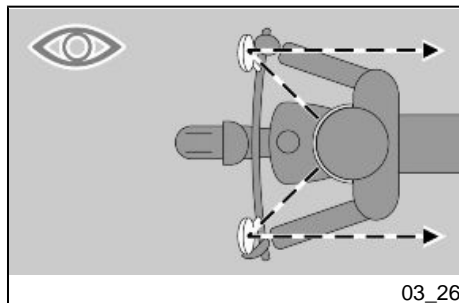
**CAUTION**

PASSENGERS MUST BE SUITABLY INSTRUCTED ON HOW TO BEHAVE TO PREVENT DANGEROUS SITUATIONS WHEN RIDING.

BEFORE SETTING OFF, MAKE SURE THE STAND HAS BEEN COMPLETELY RETRACTED TO ITS POSITION.

To start:

- Turn on the engine.
- Adjust the inclination of the rear-view mirrors to ensure proper visibility.

CAUTION

WITH THE VEHICLE AT STANDSTILL, PRACTICE USING THE REAR-VIEW MIRRORS. THE MIRRORS ARE CONVEX, SO OBJECTS MAY SEEM FARTHER AWAY THAN THEY REALLY ARE. THESE MIRRORS OFFER A WIDE-ANGLE VIEW AND ONLY EXPERIENCE HELPS YOU JUDGE THE DISTANCE SEPARATING YOU AND THE VEHICLE BEHIND.

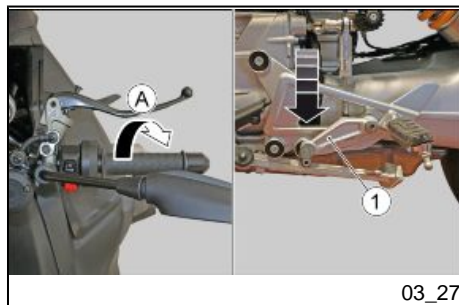

- With a closed throttle grip (Pos. A) and the engine idling, pull the clutch lever.
- Push the gearbox lever (1) downward to select the first gear.
- Release the clutch lever (activated during start-up).

CAUTION

WHEN TURNING OFF THE VEHICLE, DO NOT RELEASE THE CLUTCH TOO QUICKLY OR SUDDENLY, AS THIS COULD CAUSE THE ENGINE TO STOP OR THE VEHICLE TO REAR UP ON THE BACK WHEEL. DO NOT ACCELERATE SUDDENLY WHEN RELEASING THE CLUTCH FOR THE SAME REASON.

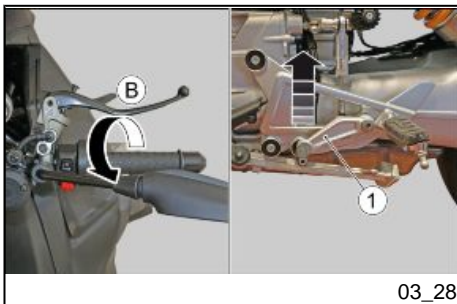

03_28

- Slowly release the clutch lever and accelerate by slightly turning the throttle grip at the same time (Pos. B).

The vehicle starts moving forward.

- Ride at moderate speed for the first kilometres/miles to allow the engine to warm up.
- Speed up by gradually turning the throttle grip (Pos. B) without exceeding the recommended revs.



RIDE IN THE CORRECT GEAR AND SPEED FOR THE CONDITIONS.

DO NOT OPERATE THE THROTTLE GRIP ABRUPTLY.

- Release the throttle grip (Pos. A), operate the clutch lever and lift the gear control lever (1), release the clutch lever and accelerate.
- Repeat the last two operations and engage a higher gear.



IT IS SUGGESTED TO GO UP TO A HIGHER GEAR THAN TO A LOWER GEAR:

- When riding downhill and under braking, using engine compression to increase braking power.
- When going uphill, when the engaged gear does not suit the speed (high gear, moderate speed) and the number of engine revs falls.

CAUTION

DOWN-SHIFT ONE GEAR AT A TIME; WHEN SHIFTING TO A LOWER GEAR, DOWN-SHIFTING MORE THAN ONE GEAR AT A TIME COULD OVER-REV THE ENGINE; THAT IS, THE MAXIMUM RPM VALUE PERMITTED FOR THE ENGINE COULD BE EXCEEDED.

- Release the throttle grip (Pos. A).
- If necessary, pull the brake levers gently and reduce speed.
- Operate the clutch lever and lower the gearshift lever (1) to engage a lower gear.
- Release the brake levers when it is operated.
- Release the clutch lever and accelerate moderately.



IN ORDER TO AVOID CLUTCH OVERHEATING, SHUT THE ENGINE OFF AS SOON AS POSSIBLE ONCE THE VEHICLE HAS STOPPED AND AT THE SAME TIME THE GEAR IS ENGAGED AND THE CLUTCH LEVER OPERATED.



OPERATE THE FRONT OR THE REAR BRAKE ONLY SIGNIFICANTLY REDUCES THE BRAKING FORCE OF THE VEHICLE.

WHEN STOPPING UPHILL, DECELERATE COMPLETELY AND ONLY USE THE BRAKES TO MAINTAIN THE VEHICLE IN THE STOPPED POSITION.

USING THE ENGINE TO KEEP THE MOTORCYCLE STOPPED COULD CAUSE THE CLUTCH TO OVERHEAT. BRAKING CONTINUOUSLY WHEN DRIVING DOWNHILL COULD CAUSE THE BRAKE PADS TO OVERHEAT, WHICH REDUCES BRAKING AND LIMITS BRAKING POWER.

IT IS RECOMMENDED TO USE THE ENGINE COMPRESSION, DOWN-SHIFTING AND USING BOTH BRAKES INTERMITTENTLY.

WHEN DRIVING DOWNHILL, NEVER RIDE WITH THE ENGINE TURNED OFF.

WHEN RIDING ON WET SURFACES OR SURFACES WITH POOR GRIP (SNOW, ICE, MUD, ETC.) USE MODERATE SPEED, AVOID SUDDEN BRAKING OR MANOEUVRES THAT MAY CAUSE TO A LOSS OF TRACTION AND POSSIBLY TO A FALL OR CRASH.

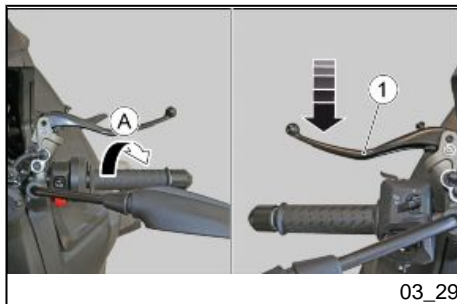

03_29

Stopping the engine (03_29)

- Release the throttle grip (Pos. A), brake gradually and simultaneously down-shift to slow down.

Once the speed is reduced, before stopping the vehicle:

- Operate the clutch lever (1) so that engine does not shut off.

When the vehicle is at standstill:

- Set the gearshift lever in neutral (symbol "N" visible on the digital display and green "N" indicator light lit).
- Release the clutch lever (1).
- While at a temporary halt, keep at least one of the vehicle brakes held.

CAUTION



WHENEVER POSSIBLE, AVOID ROUGH BRAKING, SUDDEN DECELERATION AND BRAKING IN EXCESS.

Parking

It is very important to select an adequate parking spot, in compliance with road signals and the guidelines described below.

CAUTION

PARK ON SAFE AND LEVEL GROUND TO PREVENT THE VEHICLE FROM FALLING.

DO NOT LEAN THE VEHICLE AGAINST A WALL OR LAY IT ON THE GROUND.

ENSURE THAT THE VEHICLE AND, IN PARTICULAR, PARTS OF THE VEHICLE WHICH MAY BECOME HOT (ENGINE, EXHAUST SYSTEM, BRAKE DISCS) ARE

NOT A HAZARD TO PERSONS OR CHILDREN. DO NOT LEAVE YOUR VEHICLE UNATTENDED WITH THE ENGINE ON OR THE KEY IN THE IGNITION SWITCH.

CAUTION

IF THE VEHICLE FALLS OR IS ON A STEEP INCLINE FUEL CAN LEAK.

FUEL USED TO DRIVE INTERNAL COMBUSTION ENGINES IS HIGHLY FLAMMABLE AND CAN BECOME EXPLOSIVE UNDER CERTAIN CONDITIONS.



DO NOT REST THE RIDER OR PASSENGER WEIGHT ON THE SIDE STAND.

Catalytic silencer

The vehicle is equipped a silencer with a "platinum - palladium - rhodium three-way" metal catalytic converter.

This device oxidises the CO (carbon monoxide) producing carbon dioxide, and the HC (unburned hydrocarbons) producing water vapour and CO₂ and reduces NO_x (nitrogen oxide) producing oxygen and nitrogen present in the exhaust fumes.



DO NOT PARK THE VEHICLE NEAR DRY BRUSHWOOD OR IN PLACES EASILY ACCESSIBLE BY CHILDREN BECAUSE THE CATALYTIC CONVERTER REACHES HIGH TEMPERATURES DURING VEHICLE OPERATION; FOR THIS REASON, PAY UTMOST ATTENTION AND DO NOT TOUCH IT UNTIL IT HAS COMPLETELY COOLED DOWN.



DO NOT USE LEADED PETROL AS IT CAUSES IRREPARABLE DAMAGE TO THE CATALYTIC CONVERTER.

Vehicle owners are warned that the law may prohibit the following:

- the removal of any device or element belonging to a new vehicle or any other action by anyone leading to render it non-operating, if not for maintenance, repair or replacement reasons, in order to control noise emission before the sale or delivery of the vehicle to the ultimate buyer or while it is used;
- using the vehicle after that device or element has been removed or rendered non-operating.

Check the exhaust silencer and the silencer pipes, ensuring there are no signs of penetrative corrosion and that the exhaust system works properly.

If the noise produced by the exhaust system increases, get immediately in touch with the Dealer or with a Moto Guzzi authorised repair shop.

NOTE

DO NOT TAMPER WITH THE EXHAUST SYSTEM.

Stand (03_30, 03_31)



THE SIDE STAND MUST ROTATE FREELY. IF NECESSARY GREASE THE JOINT.



SIDE STAND

If the stand has been folded up for any manoeuvre (for example, when the vehicle is in motion), place the vehicle on the stand again as follows:

- Grasp the left grip and put the right hand on the upper rear part of the vehicle.
- Push the side stand with your right foot to fully extend the stand.
- Lean the vehicle until the stand touches the ground.
- Turn the handlebar fully leftwards.

CAUTION

MAKE SURE THE VEHICLE IS STABLE.

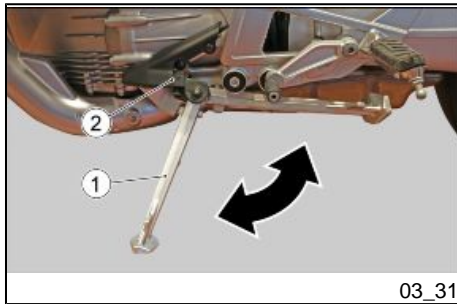

A safety switch (2) is installed on the side stand (1) to inhibit ignition or to stop the engine when a gear is engaged and the side stand (1) is lowered.

CHECK THAT THERE IS NO DIRT IN THE SWITCH AREA. IF POSSIBLE, CLEAN THE AREA AND CHECK THE LIGHT ON THE DASHBOARD WITH THE STAND DOWN.

IF WITH THE STAND OPEN, THE SIDE STAND WARNING LIGHT REMAINS OFF DESPITE CLEANING, PLEASE CONTACT an Authorised Moto Guzzi Dealer.

Suggestion to prevent theft

CAUTION

WHEN USING A DISC LOCKING DEVICE, PAY UTMOST ATTENTION TO REMOVE IT BEFORE RIDING. FAILURE TO OBSERVE THIS WARNING MAY CAUSE SERIOUS DAMAGE TO THE BRAKING SYSTEM AND ACCIDENTS WITH CONSEQUENT PHYSICAL INJURIES OR EVEN DEATH.

NEVER leave the ignition key in the lock and always use the steering lock. Park the vehicle in a safe place such as a garage or a place with guards. Whenever possible, use an additional anti-theft device. Make sure all vehicle documents are in order and the road tax paid. Write down your personal details and telephone number on this page to help identifying the owner in case of vehicle retrieval after a theft.

SURNAME:

FIRST NAME:

ADDRESS:

TELEPHONE NO.:

WARNING

IN MANY CASES, STOLEN VEHICLES CAN BE IDENTIFIED BY DATA IN THE USE / MAINTENANCE BOOKLET.

Safe driving

Some simple tips are provided below that will enable you to use your motorcycle on a daily basis in greater safety and peace of mind. Your mechanical knowledge and ability are the foundation for safe riding. We recommend trying out the motorcycle in traffic-free zones to familiarise with it.

1. Before riding off, remember to put the helmet on and fasten it correctly.
2. Slow down and drive carefully over bumpy roads.
3. After riding over a long stretch of wet road without using the brakes, braking will not be as efficient the first time/s you use them again. When riding under conditions like this, you should brake periodically.
4. Although the vehicle is equipped with an ABS system, pay attention when braking on wet surfaces, on dirt or on a slippery road surface.
5. Do not start off by getting on the vehicle while it is standing on its stand.

6. If the motorcycle is used on roads covered with sand, mud, snow mixed with salt etc., clean the brake discs frequently with a mild detergent to prevent abrasive particles from accumulating in the disc ventilation holes and causing accelerated brake pad wear.

CAUTION

TO ALLOW THE QUICK REACHING OF THE PERFECT GRIP OF NEW TYRES AT THE FIRST MILEAGE, IT IS RECOMMENDED A PARTICULARLY CAREFUL GUIDE OF THE MOTORCYCLE, AVOIDING SUDDEN STEERING OR VIOLENT ACCELERATION AND BRAKING.

CAUTION

ALWAYS RIDE WITHIN YOUR LIMITS. RIDING UNDER THE INFLUENCE OF ALCOHOL OR OTHER DRUGS AND CERTAIN MEDICINES IS EXTREMELY DANGEROUS.

CAUTION

ANY ELABORATION THAT MODIFIES THE VEHICLE'S PERFORMANCES, SUCH AS TAMPERING WITH ORIGINAL STRUCTURAL PARTS IS STRICTLY FORBIDDEN BY LAW, AND RENDERS THE MOTORCYCLE NO LONGER CONFORMING TO THE APPROVED TYPE AND DANGEROUS FOR RIDING.

CAUTION

DO NOT ADJUST THE MIRRORS WHILE RIDING. THIS COULD CAUSE YOU TO LOOSE CONTROL OF THE MOTORCYCLE.

CAUTION

STOP THE VEHICLE MAINLY USING THE FRONT BRAKE. THE REAR BRAKE MUST ONLY BE USED TO BALANCE THE BRAKING EFFECT, AND ONLY TOGETHER WITH THE FRONT BRAKE.

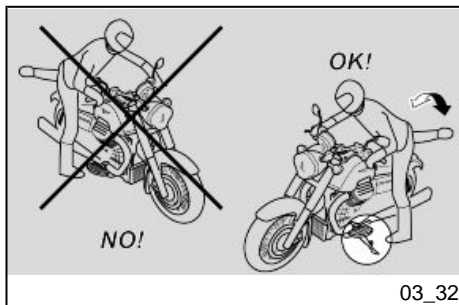

Basic safety rules (03_32, 03_33, 03_34, 03_35, 03_36)

The following recommendations should receive your maximum attention, because they are provided to increase your safety, and decrease damage to people, things and vehicles, in the case of a fall of the rider or passenger from the vehicle and/or from the fall or overturning of the vehicle.

Mounting and dismounting the vehicle should always be performed with total freedom of movement and with the hands free of all objects. (i.e.- objects, helmet, gloves, or glasses).

Mount and dismount only on the left side of the vehicle, and only with the side stand lowered.

The stand is designed to support the weight of the vehicle and a small additional weight, which does not include the rider and passenger.

Mounting into driving position, with the side stand in place, is permitted only to prevent the possibility of the vehicle falling or overturn, and does not indicate the possibility for the rider and passenger's weight to be placed on the side stand.

During mounting and dismounting the vehicle's weight can cause a loss of balance, with consequent loss of equilibrium and the possibility of falling or overturning.

CAUTION

THE RIDER SHOULD ALWAYS BE THE FIRST TO MOUNT AND THE LAST TO DISMOUNT FROM THE VEHICLE, AND SHOULD CONTROL THE STABILITY AND EQUILIBRIUM OF THE VEHICLE WHILE THE PASSENGER IS MOUNTING AND DISMOUNTING

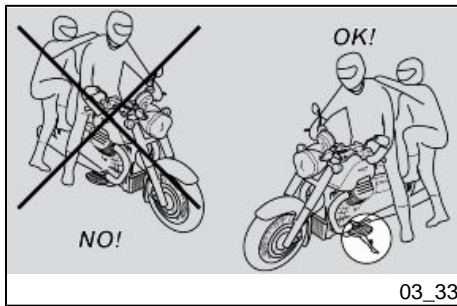

In any case, the passenger should mount and dismount the vehicle using caution to avoid causing the vehicle or the rider to lose balance.

CAUTION

THE RIDER TO INSTRUCT THE PASSENGER ABOUT THE PROPER WAY TO MOUNT AND DISMOUNT FROM THE VEHICLE.

THE VEHICLE INCLUDES PASSENGER FOOTRESTS WHICH SHOULD BE USED DURING MOUNTING AND DISMOUNTING. THE PASSENGER SHOULD ALWAYS USE THE LEFT FOOTREST FOR MOUNTING AND DISMOUNTING FROM THE VEHICLE.

DO NOT DISMOUNT OR EVEN ATTEMPT TO DISMOUNT BY JUMPING OR STRETCHING OUT YOUR LEG IN ORDER TO TOUCH THE GROUND. IN BOTH CASES THE STABILITY AND EQUILIBRIUM OF THE VEHICLE COULD BE COMPROMISED.

CAUTION

BAGGAGE OR OBJECTS ATTACHED TO THE REAR PART OF THE VEHICLE CAN CREATE AN OBSTACLE DURING MOUNTING AND DISMOUNTING FROM THE VEHICLE.

IN ALL CASES, THINK AHEAD AND MOVE YOUR RIGHT LEG CAREFULLY, AS IT WILL HAVE TO AVOID AND CLEAR THE REAR PART OF THE VEHICLE (INCLUDING BAGGAGE AND THE TAIL FAIRING) WITHOUT CAUSING LOSS OF BALANCE.

(if applicable)

NOTE

BEFORE STARTING, MAKE SURE THAT THE CASES ARE CLOSED AND CORRECTLY ATTACHED TO THE VEHICLE.



THE CASES SHALL NOT BE USED AS A SUPPORT AND THE HANDLES SHALL NOT BE USED AS ANCHORAGE FOR THE PASSENGER.

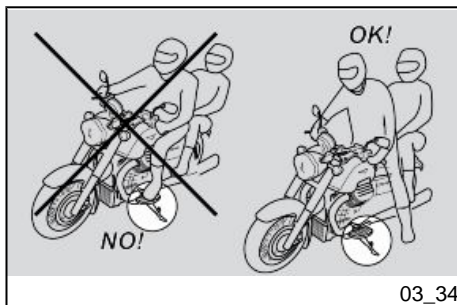

MOUNTING

- Grip the handlebar properly and mount the vehicle without placing your weight upon the side stand.

CAUTION

IN THE CASE THAT YOU ARE NOT ABLE TO REST BOTH FEET ON THE GROUND, PUT THE RIGHT FOOT ON THE GROUND, (IN THE CASE OF A LOSS OF BALANCE THE LEFT SIDE IS "PROTECTED" BY THE SIDE STAND) AND KEEP YOUR LEFT FOOT READY TO BE POSITIONED.

- Place both feet on the ground and straighten the vehicle into the driving position, always maintaining its equilibrium.

CAUTION

THE RIDER SHOULD NOT OPEN OR TRY TO OPEN THE PASSENGER FOOTRESTS FROM THE RIDER'S SEAT, AS IT COULD COMPROMISE THE STABILITY AND EQUILIBRIUM OF THE VEHICLE.

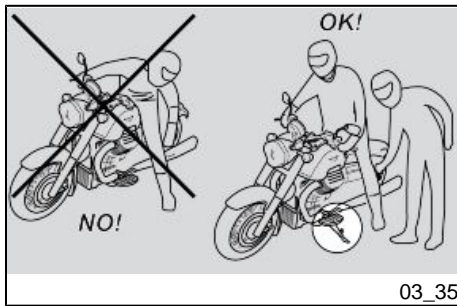

- Have the passenger open the two passenger foot pegs.
- Show the passenger how to mount the vehicle.
- Use your left foot to push on the side stand and make it fully return to its position.

DISMOUNTING

- Select an appropriate parking spot.
- Stop the vehicle.



MAKE SURE THAT THE GROUND ON WHICH THE MOTORCYCLE IS PARKED IS FIRM, EVEN AND FREE OF OBSTACLES.

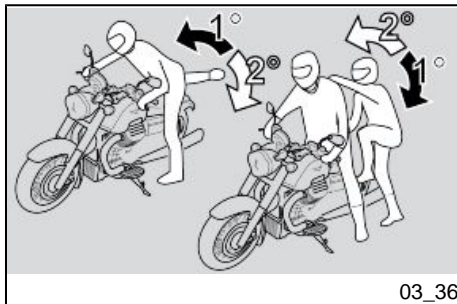

- Use the heel of your left foot to completely open the side stand.

CAUTION

IN THE CASE THAT YOU ARE NOT ABLE TO REST BOTH FEET ON THE GROUND, PUT THE RIGHT FOOT ON THE GROUND, (IN THE CASE OF A LOSS OF BALANCE THE LEFT SIDE IS "PROTECTED" BY THE SIDE STAND) AND KEEP YOUR LEFT FOOT READY TO BE POSITIONED.

- Place both feet on the ground and keep the vehicle balanced in the driving position.
- Show the passenger how to dismount from the vehicle.



RISK OF FALLING OR OVERTURNING.

MAKE SURE THAT THE PASSENGER HAS DISMOUNTED FROM THE VEHICLE.

DO NOT PLACE YOUR WEIGHT UPON THE SIDE STAND.

- Lean the motorcycle until the stand touches the ground.
- Correctly grip the handlebar, and dismount from the vehicle.
- Turn the handlebar completely to the left.
- Place the passenger footrest in its place.

CAUTION**MAKE SURE THE VEHICLE IS STABLE.**

V100 Mandello - V100 Mandello S



**Chap. 04
Maintenance**

Foreword

In general terms, scheduled maintenance can be carried out by the owner; however, some operations may require specific tools and technical training. For periodic maintenance, servicing or technical advice, contact an **Official Moto Guzzi Dealer** for prompt and accurate service.

CAUTION

THIS VEHICLE HAS BEEN PROGRAMMED TO INDICATE IN REAL TIME ANY ACTIVATION FAILURE STORED IN THE ELECTRONIC CONTROL UNIT MEMORY.

ANY TIME THE IGNITION SWITCH IS SET TO "ON", THE "GENERAL ALARM" WARNING LIGHT ON THE INSTRUMENT PANEL TURNS ON FOR THREE SECONDS. IF THE WARNING LIGHT TURNS OFF, IT MEANS THAT THERE ARE NO MALFUNCTIONS.

CAUTION

CARRY OUT MAINTENANCE OPERATIONS AT HALF THE INTERVALS SPECIFIED IF THE VEHICLE IS USED IN PARTICULAR RAINY OR DUSTY CONDITIONS, OFF ROAD OR FOR TRACK USE.

Engine oil level check (04_01, 04_02)

Check the engine oil level frequently.

NOTE

THE MAINTENANCE INTERVALS PRESCRIBED BY THE SCHEDULED MAINTENANCE TABLE MUST BE CONSIDERED AS A GENERAL GUIDE FOR USING THE VEHICLE IN NORMAL RUNNING CONDITIONS.

IT MAY BE NECESSARY TO REDUCE THE MAINTENANCE INTERVALS UNDER SOME PARTICULAR CONDITIONS. ESPECIALLY WHEN USED IN GEOGRAPH-

ICAL LOCATIONS WITH ADVERSE CLIMATIC CONDITIONS, USE ON UNEVEN GROUND OR SEVERE INDIVIDUAL USE.



THE OIL LEVEL MUST BE CHECKED WHEN THE ENGINE IS WARM.

CAUTION

DO NOT LET THE ENGINE IDLE WITH THE VEHICLE AT A STANDSTILL TO WARM UP THE ENGINE AND OBTAIN THE OPERATING TEMPERATURE OF ENGINE OIL.

PREFERABLY CHECK THE OIL AFTER A JOURNEY OF AFTER TRAVELLING APPROXIMATELY 15 Km (10 miles) IN EXTRA-URBAN CONDITIONS (ENOUGH TO WARM UP THE ENGINE OIL TO OPERATING TEMPERATURE).

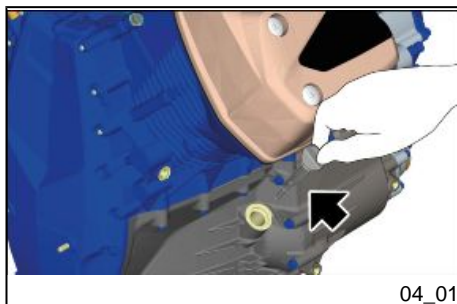

- Shut off the engine and wait a few seconds;
- Keep the vehicle upright with both wheels on the ground;
- Make sure that the vehicle is on a level surface;
- Unscrew the oil filler cap with dipstick;

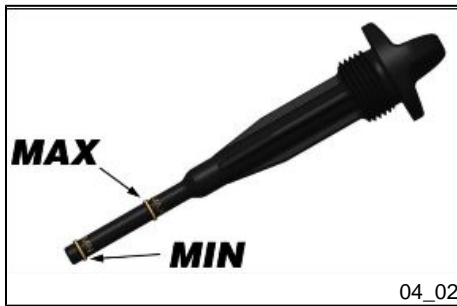

- Wipe the dipstick clean and put the dipstick and filler cap back into place **without tightening**;
- Remove the cap and dipstick again and check the engine oil level;
- The level is correct if it reaches the "MAX" level approximately. Otherwise top off the engine oil.

CAUTION

THE OIL LEVEL MUST NEVER DROP BELOW THE MINIMUM MARKING OR EXCEED THE MAXIMUM MARKING; AN OIL LEVEL NOT WITHIN THE MINIMUM AND MAXIMUM MARKINGS MAY CAUSE SEVERE ENGINE DAMAGE.

Engine oil top-up

CAUTION

IF IT IS NECESSARY TO TOP UP THE ENGINE OIL LEVEL, CONTACT AN official Moto Guzzi dealer.

Engine oil change

CAUTION

THE ENGINE OIL MUST BE CHECKED AND CHANGED BY AN Official Moto Guzzi Dealership

Engine oil filter replacement

CAUTION

THE ENGINE OIL FILTER MUST BE CHECKED AND CHANGED BY AN Official Moto Guzzi Dealership

Bevel gear pair oil level

CAUTION

TO TOP-UP OR CHANGE THE OIL IN THE CARDAN SHAFT TRANSMISSION UNIT, CONTACT AN Official Moto Guzzi Dealer.

Tyres (04_03, 04_04)

This vehicle is fitted with tubeless tyres (without inner tubes).

CAUTION

CHECK TYRE INFLATION PRESSURE REGULARLY AT AMBIENT TEMPERATURE. MEASUREMENTS MAY BE INCORRECT IF TYRES ARE WARM. CHECK PRESSURE MAINLY BEFORE AND AFTER LONG TRIPS. AN OVER-INFLATED TYRE WILL PROVIDE A HARSH RIDE AS SURFACE UNEVENNESS IS NOT CUSHIONED AND IS SENT TO THE HANDLEBAR, THUS REDUCING GRIP AND ROAD HOLDING SPECIALLY WHEN CORNERING.

ON THE OTHER HAND, AN UNDER-INFLATED TYRE CAUSES THE CONTACT PATCH TO INCLUDE A LARGER PORTION OF THE TYRE SIDE WALLS. IF SO, THE TYRE MIGHT SLIP ON OR GET DETACHED FROM THE WHEEL RIM, RESULTING IN LOSS OF CONTROL OVER THE VEHICLE.

EVENTUALLY THE VEHICLE MIGHT SKID IN A BEND.

CHECK THE SURFACE CONDITION AND WEAR BECAUSE POOR TYRE CONDITION COULD COMPROMISE GRIP AND HANDLING OF THE VEHICLE.

SOME TYRE TYPES APPROVED FOR THIS VEHICLE FEATURE WEAR INDICATORS.

THERE ARE SEVERAL TYPES OF WEAR INDICATORS. CONSULT YOUR DEALER ON METHODS TO CHECK FOR WEAR.

CARRY OUT A VISUAL INSPECTION FOR TYRE WEAR AND TEAR, REPLACE TYRES WHEN WORN.

WHEN TYRES ARE OLD, THE MATERIAL MAY HARDEN AND NOT PROVIDE ADEQUATE ROAD HOLDING, EVEN IF TYRES ARE STILL WITHIN THE WEAR LIMIT. REPLACE TYRES IF THIS OCCURS. REPLACE THE TYRE IF IT IS WORN OR IF THERE IS A PUNCTURE LARGER THAN 5 mm (0.197 in) IN THE TREAD AREA.

WHEEL MUST BE BALANCED AFTER A TYRE IS MENDED.

USE ONLY TYRE SIZES INDICATED BY THE MANUFACTURER. DO NOT FIT TYRES WITH INNER TUBES ON RIMS FOR TUBELESS TYRES OR VICE VERSA. CHECK THAT THE INFLATION VALVES HAVE THEIR CAPS FITTED TO AVOID UNEXPECTED FLAT TYRES.

REPLACEMENT, REPAIR, MAINTENANCE AND BALANCING OPERATIONS ARE HIGHLY IMPORTANT AND SO THEY SHOULD BE CARRIED USING THE SPECIFIC TOOLS AND WITH ADEQUATE EXPERTISE. HAVE YOUR TYRES AND WHEELS SERVICED AT AN AUTHORISED DEALER OR A SPECIALISED TYRE WORKSHOP.

NEW TYRES MAY BE COATED WITH AN OILY FILM: RIDE WITH CAUTION DURING THE FIRST KILOMETRES. DO NOT APPLY UNSUITABLE LIQUIDS ON TYRES.

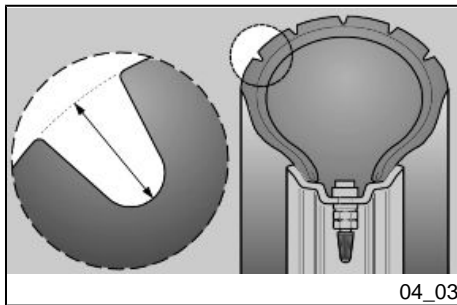

Minimum tread depth:

front and rear 2 mm (0.079 in) (USA 3 mm) (USA 0.118 in) and anyway not lower to what it is specified in the current legislation in the country in which the vehicle is used.

**(if applicable)**

The vehicle is equipped with TPMS sensors (Tyre Pressure Measurement System) located on the inside of the rims near the inflation valves; they communicate the tyre pressure to the digital display via radio frequency.

A screen can be viewed on the digital display where the reference values and any warning signals (if active) are constantly visible.

Possible warnings are accompanied by the fixed lighting of the TPMS icon, visible both in the various driving modes and in the NAVI mode.

When replacing tires, pay close attention to the following information:

- The bead breaking of the tyre must take place at a distance of at least 90° from the inflation valve.
- The positioning of the levers for the removal of the tyre must be at a distance of at least 10 cm (3.93 in) from the inflation valve.

Spark plug dismantlement

CAUTION

FOR REMOVAL, CHECK, AND REPLACEMENT OF THE SPARK PLUGS CONTACT AN OFFICIAL Moto Guzzi Dealer.

Removing the air filter

CAUTION

TO REMOVE, CHECK AND REPLACE THE AIR FILTER, CONTACT AN Official Moto Guzzi Dealer.

Cooling fluid level

Do not use the vehicle if the coolant level is below the minimum marking.

CAUTION



COOLANT IS TOXIC IF INGESTED; CONTACT WITH YOUR EYES OR SKIN MAY CAUSE IRRITATION. IF THE FLUID GETS IN CONTACT WITH THE EYES OR SKIN, RINSE REPEATEDLY WITH PLENTY OF WATER AND SEEK MEDICAL ADVICE. IF SWALLOWED, INDUCE VOMITING, RINSE THE MOUTH AND THROAT WITH PLENTY OF WATER AND SEEK MEDICAL ADVICE IMMEDIATELY.

CAUTION



NEVER UNDO THE RADIATOR CAP WHEN THE ENGINE IS WARM, AS THE COOLANT IS PRESSURISED AND VERY HOT. CONTACT WITH SKIN OR CLOTHES MAY CAUSE SEVERE BURNS AND/OR INJURIES.



04_05

Coolant check (04_05)

- Shut off the engine and wait until it cools off.
- Keep the vehicle upright with both wheels on a flat surface.
- Looking from right side of the vehicle, behind the front fork, make sure that the fluid level in the expansion tank is between the reference marks (1) "MAX" and (2) "MIN".
- Top up immediately if the fluid level is below the "MIN" level.



04_06

Coolant top-up (04_06)

- With the engine stopped and cold, remove the cap from the expansion tank and add coolant to bring the level between the (1) "MAX" and (2) "MIN" reference marks.

WARNING

CARRY OUT THE CHECK AND TOP UP THE REFRIGERANT LIQUID WITH THE ENGINE SWITCHED OFF AND COLD.



TO REPLACE THE COOLANT, CONTACT AN Official Moto Guzzi Dealer

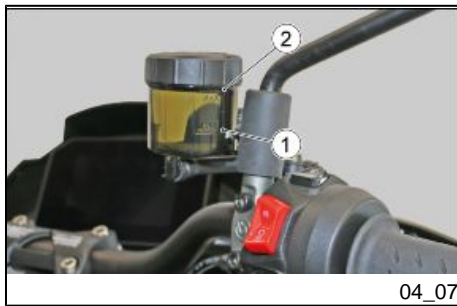

04_07

Checking the brake oil level (04_07, 04_08)

Front brake fluid check

- Keep the vehicle upright so that the fluid in the reservoir is at the same level as the plug.
- Check that the fluid in the tank is between the marks (1) and (2).

(1): **MIN** = minimum level

(2): **MAX** = maximum level

If the fluid does not reach at least the "**MIN**" reference mark:

- Check the brake pads and discs for wear.

If the brake pads and/or brake discs do not have to be replaced, have the braking system checked at an **Official Moto Guzzi Dealership**.

CAUTION

FLUID LEVEL DECREASES GRADUALLY AS BRAKE PADS WEAR DOWN.

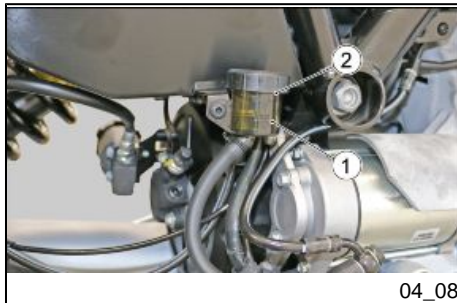

04_08

Rear brake fluid check

- Keep the vehicle upright so that the fluid in the reservoir is at the same level as the plug.
- Check that the fluid in the tank is between the marks (1) and (2).

(1): **MIN** = minimum level

(2): **MAX** = maximum level

If the fluid does not reach at least the "**MIN**" reference mark:

- Check the brake pads and disc for wear.

If the brake pads and/or brake disc do not have to be replaced, have the braking system checked at an **Official Moto Guzzi Dealership**.

CAUTION

FLUID LEVEL DECREASES GRADUALLY AS BRAKE PADS WEAR DOWN.

Braking system fluid top up

CAUTION

FOR THE TOP-UP OF THE BRAKING SYSTEMS COOLANT, CONTACT AN Official Moto Guzzi Dealer.

Checking clutch fluid (04_09)

Clutch fluid level check

- Keep the vehicle upright so that the fluid in the reservoir is at the same level as the plug.
- Check that the fluid in the tank is between the marks (1) and (2).

(1): **MIN** = minimum level

(2): **MAX** = maximum level

If the fluid does not reach the "**MIN**" reference, have the clutch system checked by an **Official Moto Guzzi dealer**.

Topping up clutch fluid

CAUTION

FOR THE TOP-UP OF THE CLUTCH FLUID, CONTACT AN Official Moto Guzzi Dealer

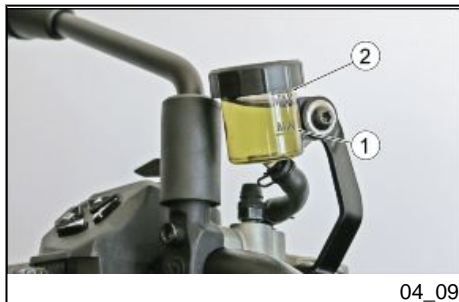

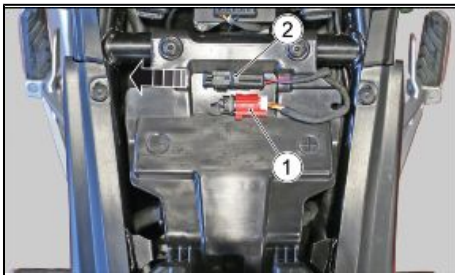

04_10

Battery removal (04_10, 04_11, 04_12, 04_13)

- Make sure the ignition switch is set to "KEY OFF";
- Remove the rider saddle;
- Disconnect the connector (1) of the OBD2 socket;
- Remove the cable (2) of the GMP provision, moving it forward to release it from its support;



04_11

- Remove the two fixing screws (3);

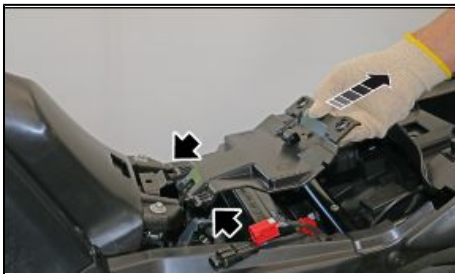

04_12

- Release the plastic securing the battery from its mountings to the tank and remove it by bringing it toward the rear of the vehicle.

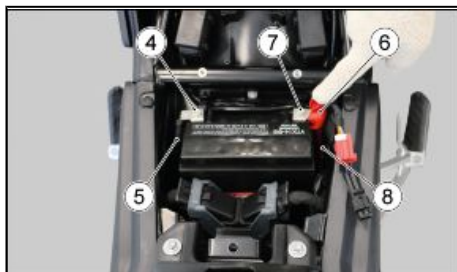

04_13

- Unscrew and remove the screw (4) from the negative terminal (-).
- Move the negative lead (5) aside.
- Move the protection cap (6), unscrew and remove the screw (7) from the positive terminal (+).
- Move the positive lead (8) aside.
- Grip the battery firmly and remove from its seat.
- Put the battery away on a level surface, in a cool and dry place.



CHECK THAT THE CABLE TERMINALS AND BATTERY LEADS ARE:

- IN GOOD CONDITION (NOT CORRODED OR COVERED BY DEPOSITS);
- COVERED BY NEUTRAL GREASE OR PETROLEUM JELLY.



REMOVING THE BATTERY RESETS THE DIGITAL CLOCK AND THE TRIP JOURNAL FUNCTIONS.

CAUTION



ONCE REMOVED, THE BATTERY MUST BE PUT AWAY IN A SAFE PLACE OUT OF THE REACH OF CHILDREN.

CAUTION

UPON REFITTING, CONNECT THE LEAD TO THE POSITIVE TERMINAL (+) FIRST AND AFTERWARDS THE LEAD TO THE NEGATIVE TERMINAL (-).

Checking the electrolyte level

WARNING

THIS VEHICLE IS FITTED WITH A MAINTENANCE-FREE BATTERY AND DOES NOT NEED ANY INTERVENTION, EXCEPT FOR SPORADIC CHECKS AND RECHARGE.

Charging the battery

- Remove the battery.
- Get an adequate battery charger.
- Set the battery charger for the recharge type indicated.
- Connect the battery to the battery charger.

CAUTION



WHEN RECHARGING OR USING THE BATTERY, BE CAREFUL TO HAVE THE ROOM ADEQUATELY AIRED. DO NOT BREATHE GASES RELEASED WHEN THE BATTERY IS RECHARGING.

- Switch on the battery charger.

CHARGE MODES

Normal recharge

- Electric current: 1,4 A
- Time: 5-10 hours

Quick charge

- Electric current: 6 A

- Time: 1 hours

Long periods of inactivity

If the vehicle is inactive longer than fifteen days, it is necessary to recharge the battery to avoid sulphation.

- Remove the battery and put it away in a cool and dry place.

In winter or when the vehicle is out of use for prolonged periods, check charge level frequently (about once a month) to prevent deterioration.

- Recharge it fully with an ordinary charge.

If the battery is still on the vehicle, disconnect the cables from the terminals.

Checking and cleaning terminals and leads

- Partially remove the battery from its housing.
- Check that the battery cable terminals and leads are in good conditions (not corroded or covered by deposits) and covered with neutral grease or petroleum jelly.

Fuses (04_14, 04_15, 04_16, 04_17)

CAUTION



DO NOT ATTEMPT TO REPAIR FAULTY FUSES.

NEVER USE A FUSE THAT IS DIFFERENT THAN WHAT IS SPECIFIED TO PREVENT DAMAGES TO THE ELECTRICAL SYSTEM OR SHORT CIRCUITS, AND THE RISK OF FIRE.



04_14

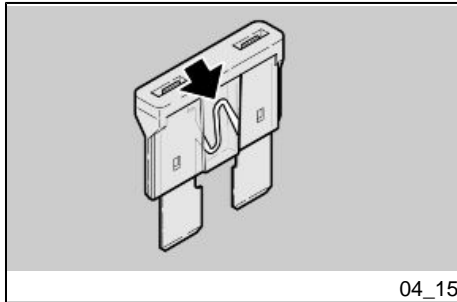

04_15

NOTE

A FUSE THAT BLOWS FREQUENTLY MAY INDICATE A SHORT CIRCUIT OR OVERLOAD. IF THIS OCCURS, CONTACT AN Official Guzzi Dealer.

To check:

- Set the ignition switch to 'OFF' to avoid an accidental short circuit;
- Remove the passenger saddle;
- Remove the fuse box cover;
- Take out one fuse at a time and check if the filament is broken;
- Before replacing the fuse, find and solve, if possible, the reason that caused the problem;
- If the fuse is damaged, replace it with one of the same current rating.

NOTE

IF THE SPARE FUSE IS USED, REPLACE WITH ONE OF THE SAME TYPE IN THE CORRESPONDING FITTING.

MAIN FUSES

40A fuse	Charging the battery
30A fuse	Loads of the entire vehicle

spare fuses

They are located under the tank, in front of the E.C.U.

If there is a problem with the main fuses, DO NOT replace them, but take your vehicle to an Official Moto Guzzi dealer.



AUXILIARY FUSES (1)

A) 10A fuse	Rear position, horn, licence plate light
B) 5A fuse	Fog lights live positive lead (where provided)
C) 7.5A fuse	ECU key-on positive, ABS key-on positive, instrument panel key-on positive, RH light switch key-on positive, inertial platform key-on positive, stand key-on positive, TMPS key-on positive (if provided),

	rear radar key-on positive (if provided), main ignition relay
D) 7.5A fuse	Key-on power for smart EC key-on positive (if provided)
E) 7.5A fuse	GMP key-on positive (if provided), OBD key-on positive, anti-theft system positive
F) 7.5A fuse	Headlamp key-on positive
G) 3A fuse	USB 1 and 2 key-on positive (2 if provided)
Q) Spare fuses	

They are located on the tail fairing, under the passenger saddle

AUXILIARY FUSES (2)

H) 15A fuse	Power supply for: Fan relay, ECU, fuel pump relay, RH and LH lambda probe, RH and LH injectors, RH and LH coils, secondary air valve, urge valve
I) 5A fuse	Power supply for: anti-theft device provision, OBD2
L) 7.5A fuse	Fan power feed
M) 7.5A fuse	ECU permanent positive lead
N) fuse of 10A	MGCA aerodynamic protection power supply

O) 5A fuse	Instrument panel power supply (turn indicators)
------------	--

P) 20A fuse	ABS power feed
-------------	----------------

Q) Spare fuses

They are located on the tail fairing, under the passenger saddle

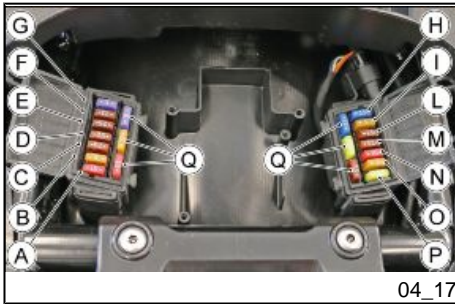

Front light group (04_18, 04_19, 04_20)

The headlamp unit uses LED light sources only, and consists of the following modules:

- two low beam headlight modules (1);
- one high beam headlight module (2);
- A DRL / position module (with low beam switched on) (3);
- two bending light modules (to assist rider in bends) (4).

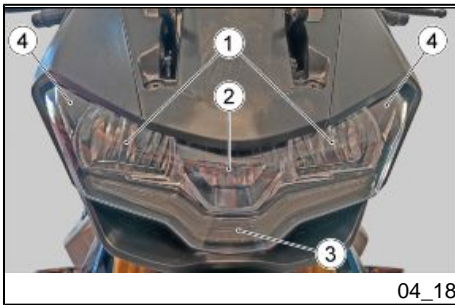
**NOTE**

WHEN THE REAR WHEEL EXCEEDS THE SPEED OF 1 km/h (0.62 mph) (EVEN WITH THE ENGINE OFF, AND THE KEY SET TO ON), THE HEADLIGHTS WILL TURN ON AND WILL REMAIN ON FOR 30 SECONDS (FROM THE TIME IN WHICH THE REAR WHEEL STOPS MOVING).



The 'bending light' modules (4) are activated when the vehicle reaches or exceeds a 25 degree angle when cornering, and only when the low beam is switched on.

- When leaning into a right hand turn, the right hand LED bending assist light illuminates (A).



- When leaning into a left hand turn, the left hand LED bending assist light illuminates (A).

CAUTION

TO REMOVE, CHECK AND REPLACE THE FRONT LIGHT ASSEMBLY LAMPS, CONTACT AN Authorised Moto Guzzi Dealership

Headlight adjustment (04_21, 04_22, 04_23)**NOTE**

IN COMPLIANCE WITH LOCAL LEGAL REQUIREMENTS, SPECIFIC PROCEDURES MUST BE FOLLOWED WHEN CHECKING LIGHT BEAM ADJUSTMENT.

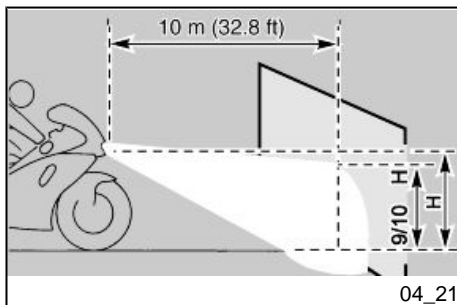
**For a quick check of the correct direction of the front light beam:**

- Place the vehicle 10 m (32.81 ft) away from a vertical wall and make sure the ground is level.
- Turn on the low beam light, sit on the vehicle and check that the light beam projected to the wall is a little below the headlight horizontal straight line (about 9/10 of the total height).

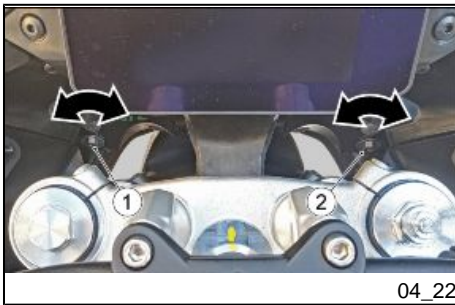

04_22

To carry out vertical adjustment of the light beam:

- Place the vehicle in a vertical position;
- Adjust the adjusting screws (1) and (2), located under the instrument panel, to adjust the (1) left and (2) right **low beam** headlamps. Turning the screw clockwise lowers the headlamp, and counterclockwise raises the headlamp.



04_23

- Using a Phillips screwdriver, turn the adjustment screw that can be reached from under the top fairing to adjust the **high beam** headlight. Turning the screw clockwise lowers the headlamp, and counterclockwise raises the headlamp.

Front direction indicators

NOTE

TO REMOVE, CHECK AND REPLACE THE FRONT TURN INDICATORS, PLEASE CONTACT AN Authorised Moto Guzzi Dealership

Rear optical unit

CAUTION

TO REMOVE, CHECK AND REPLACE THE REAR LIGHT ASSEMBLY, CONTACT AN Authorised Moto Guzzi Dealership.

Rear turn indicators

NOTE

FOR DISASSEMBLY, VERIFICATION AND REPLACEMENT OF REAR INDICATORS PLEASE CONTACT AN Official Moto Guzzi Dealership

Rear-view mirrors (04_24, 04_25)



DO NOT RIDE WITH REAR-VIEW MIRRORS INCORRECTLY SET.

ALWAYS CHECK THAT THE MIRRORS ARE ADJUSTED CORRECTLY BEFORE SETTING OFF.

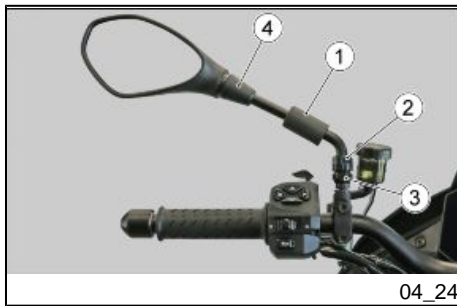

Removing the rear-view mirrors:

- Rest the vehicle on its stand.
- Lift the rubber protection (1).
- Loosen the fastening nut (2) by ensuring that the threaded clamp (3) cannot rotate.
- Slide up and remove the complete rear-view mirror unit (4).

Repeat the procedure to remove the other rear-view mirror, if necessary.



UPON REFITTING AND BEFORE TIGHTENING THE LOCKING NUT, MAKE SURE THAT THE REAR VIEW MIRROR SUPPORT STEM IS ALIGNED WITH THE HANDLEBAR.

CAUTION

THE VEHICLE MAY NOT BE RIDDEN ON PUBLIC ROADS WITH THE REAR VIEW MIRRORS REMOVED.

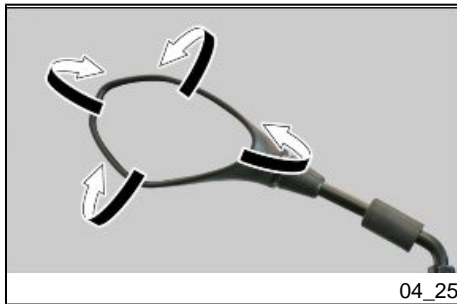

Rear-view mirrors adjustment:

- Get onto the bike in the riding position.
- Turn the mirror, correctly adjusting the inclination.

Repeat the procedure to adjust the other mirror.

- Make sure there is no dirt or mud.

Front and rear disc brake (04_26, 04_27, 04_28)

CAUTION



A DIRTY DISC SMEARS THE PADS RESULTING IN POOR BRAKING.

REPLACE DIRTY PADS AND CLEAN AGAIN THE DIRTY DISC USING A TOP QUALITY DEGREASING PRODUCT.

CAUTION

TAKE YOUR VEHICLE TO AN Official Moto Guzzi Dealer TO HAVE THE FRONT WHEEL REMOVED.

CAUTION



CHECK BRAKE PADS FOR WEAR MAINLY BEFORE EACH RIDE.

To perform a quick pad wear check:

- Rest the vehicle on its stand.
- Carry out a visual inspection of brake disc and pads as follows:
 - from the top rear side to check the front brake callipers (1);
 - from the bottom rear side to check the rear brake calliper (2).

CAUTION

EXCESSIVE WEAR OF THE FRICTION MATERIAL MAKES THE PAD METAL SUPPORT GET INTO CONTACT WITH THE DISC, WHICH RESULTS IN A METALLIC NOISE AND SPARKS IN THE CALLIPER; THEREFORE, BRAKING EFFICIENCY AND DISC SAFETY AND INTEGRITY ARE AT RISK.

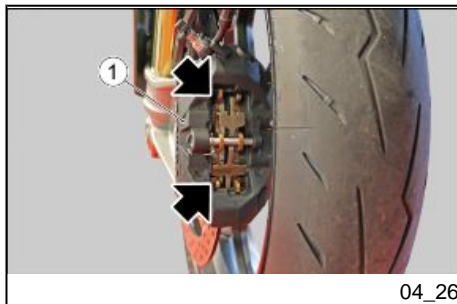

04_26

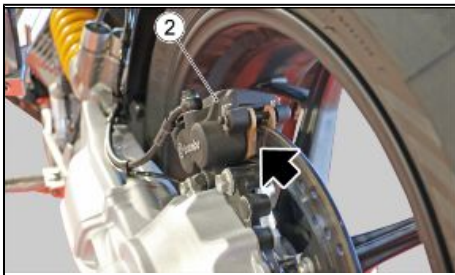

04_27

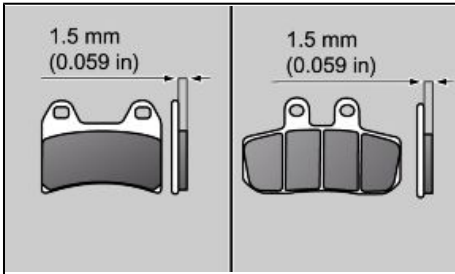

04_28

If the friction material thickness (even of one front or rear pad) is reduced to a value of about **1.5 mm (0.059 in)** (or even if one of the wear indicators is not very visible), contact an **Official Moto Guzzi Dealer** to replace all the brake callipers.

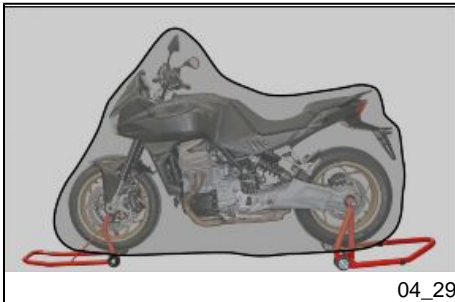

04_29

Periods of inactivity (04_29)

A number of precautionary measures must be taken to prevent the possible consequences of prolonged lack of usage of the vehicle. Besides, it is necessary to carry out general repairs and checks before garaging the motorcycle as one can forget to do so afterwards.

Proceed as follows:

- Remove the battery.
- Wash and dry the motorcycle.
- Apply wax polish to painted and chromed surfaces.
- Inflate the tyres.

- Store the motorcycle in a cool, dry place, not exposed to sun rays and with minimum temperature variations.
- Wrap and tie a plastic bag around the exhaust pipe opening to keep moisture out.

CAUTION

PLACE THE VEHICLE ON SUITABLE SUPPORTS TO KEEP THE TYRES OFF THE GROUND.

Cover the vehicle but do not use plastic or waterproof materials.

CAUTION

TO AVOID BATTERY DETERIORATION, FOLLOW THE PROCEDURE DESCRIBED FOR PROLONGED INACTIVITY.

AFTER STORAGE**NOTE**

TAKE THE PLASTIC BAGS OFF THE EXHAUST PIPE OPENING.

- Uncover and clean the vehicle.
- Check the battery for correct charge and install it.
- Refill the fuel tank.
- Carry out the pre-ride checks.

CAUTION

AS A TEST, RIDE THE MOTORCYCLE FOR A FEW KILOMETRES AT A MODERATE SPEED AND AWAY FROM TRAFFIC AREAS.



04_30

Cleaning the vehicle (04_30, 04_31, 04_32)

Moto Guzzi recommends using quality products for cleaning the vehicle. The use of unsuitable products can damage vehicle components. For cleaning do not use solvents such as "nitro thinner", "cold cleaning agents", or similar fuels, or cleaning products that contain alcohol.

WASHING THE MOTORCYCLE

Moto Guzzi recommends softening with water and then carefully removing the insects and stubborn stains before washing the vehicle.

To prevent stains, do not wash the motorcycle immediately after exposure to sunlight, and do not wash it in the sun.

If the vehicle is used during the winter months, be sure to frequently wash the motorcycle. To remove anti-icing salt sprayed on roads in the winter, wash the motorcycle with cold water immediately after use.



USE OF HOT WATER INTENSIFIES THE EFFECT OF THE SALT. USE ONLY PLENTY OF COLD WATER TO WASH AND REMOVE ANTI-ICING SALT



USE OF HIGH PRESSURE WASHING SYSTEMS (OR STEAM CLEANERS) CAN DAMAGE THE SEALS, OIL SEALS, BRAKING SYSTEM, ELECTRICAL SYSTEM AND THE SADDLE. DO NOT USE STEAM OR HIGH PRESSURE CLEANING SYSTEMS. DO NOT USE STEAM OR HIGH PRESSURE CLEANING SYSTEMS. DO NOT INSIST WITH THE PRESSURE NOZZLE ON THE WHEEL BEARINGS, INSIDE THE REAR WHEEL HUB, ON THE HYDRAULIC BRAKING CIRCUIT AND ON THE ELECTRICAL PARTS.

CLEANING OF SENSITIVE PARTS

BODYWORK

To keep the motorcycle bright, wash it regularly, especially if used in areas with high levels of pollution or mud. Aggressive stains from tree resins, gasoline, oil, brake fluid or bird excrement in general.

must be removed immediately, otherwise permanent stains on the paint can appear. After washing is easy to identify marks and residual stains, remove these from the bodywork using a soft cloth, of a non-abrasive polish brand. Periodic care, a thorough cleaning of the bodywork preserves the aesthetic quality of the motorcycle over the long term.

PLASTIC COMPONENTS



IF THE PLASTIC COMPONENTS ARE CLEANED USING AGGRESSIVE AGENTS, THE SURFACE MAY BE DAMAGED. DO NOT USE CLEANING PRODUCTS CONTAINING ALCOHOL, SOLVENTS OR THAT ARE ABRASIVE FOR THE CLEANING OF PLASTIC PARTS. ROTARY BRUSHES OR SPONGES WITH HARD SURFACES CAN MAKE SCRATCHES

FRONT HEADLIGHT

Do not use products containing aggressive agents during use or during washing, due to the structure of the bottom bracket cup, under the frame can be detected water or dirt.

Since water outside the headlight will dry due to the heat and ventilation during use of the motorcycle, in case of persistence use compressed air at a distance of 10 cm from the headlight.



TO CLEAN THE HEADLIGHTS USE A SPONGE SOAKED IN WATER AND MILD DETERGENT, RUBBING THE SURFACE GENTLY AND RINSING FREQUENTLY WITH PLENTY OF WATER. DO NOT POLISH MATT-PAINTED SURFACES WITH

POLISHING PASTE. THE VEHICLE SHOULD NEVER BE WASHED IN DIRECT SUNLIGHT, ESPECIALLY DURING SUMMER, OR WITH THE BODYWORK STILL HOT AS THE CAR SHAMPOO CAN DAMAGE THE PAINTWORK IF IT DRIES BEFORE BEING RINSED OFF.

CAUTION**WARNING**

AFTER HEAVY RAIN, WASHING OR IN CASE OF RAPID TEMPERATURE CHANGES, THE LENSES OF THE FRONT LIGHT ASSEMBLY MAY BECOME FOGGY.

THIS STATE IS DUE TO THE TEMPERATURE DIFFERENCE BETWEEN THE OUTSIDE AND THE INSIDE AND DOES NOT INDICATE A FAULT OF THE FRONT LIGHT ASSEMBLY.

CHROME PARTS AND POLISHED METAL

TREAT THE PARTS MADE OF CHROME, ALUMINIUM OR POLISHED STEEL IN A SPECIAL MANNER. WASH THEM WITH PLENTY OF WATER AND CAR SHAMPOO, POLISH AND REGULARLY BRIGHTEN THEM WITH DEDICATED PASTE, PROTECT THEM WITH SUITABLE ACID-FREE PRODUCTS (E.G. VASELINE)

RUBBER PARTS

Clean the rubber parts using water and mild shampoo (brand-name, suitable for car bodies)



THE USE OF SILICONE SPRAY TO CLEAN THE RUBBER SEALS MAY CAUSE DAMAGE. DO NOT USE OTHER PRODUCTS CONTAINING SILICON FOR CLEANING THE MOTORCYCLE

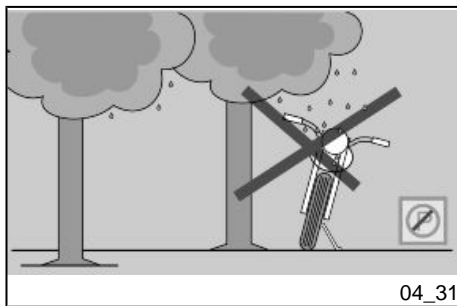

Clean the motorcycle frequently if exposed to adverse conditions, such as:

- Air pollution (cities and industrial areas).
- Salinity and humidity in the atmosphere (seashore areas, hot and wet weather).
- Special environmental/seasonal conditions (use of salt, anti-icing chemical products on the roads in winter).
- Always clean off any smog and pollution residue, tar stains, insects, bird droppings, etc. from the bodywork.
- Avoid parking the vehicle under trees. During some seasons, resins, fruits or leaves containing aggressive chemical substances that may damage the paintwork may fall from trees.

CAUTION



BEFORE WASHING THE VEHICLE, COVER THE ENGINE AIR INTAKES AND THE EXHAUST PIPES.

CAUTION



CLEAN THE INSTRUMENT PANEL WITH A SOFT CLOTH MOISTENED WITH WATER.

CAUTION

AFTER CLEANING YOUR MOTORCYCLE, BRAKING EFFICIENCY MAY BE TEMPORARILY AFFECTED DUE TO THE PRESENCE OF WATER ON THE FRICTION SURFACES OF THE BRAKING CIRCUIT. ALLOW LONGER BRAKING DISTANCES TO PREVENT ACCIDENTS. BRAKE REPEATEDLY TO RESTORE NORMAL OPERATION. CARRY OUT THE PRE-RIDE CHECKS.

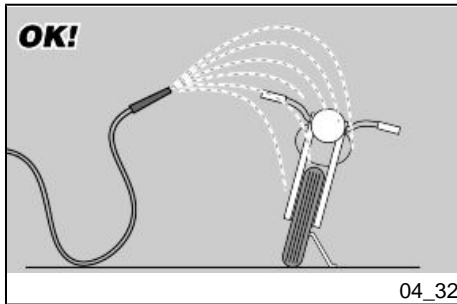

To remove dirt and mud accumulated on painted surfaces, wet the soiled areas thoroughly with a low-pressure water jet, then remove dirt and mud with a soft car body sponge soaked abundantly in a solution of car body shampoo in water (2 - 4% shampoo dissolved in water). Then rinse with plenty of water, and dry with a chamois leather. To clean the engine outer parts, use degreasing detergent, brushes and old cloths. Wash anodised or painted aluminium parts with neutral soap and water. Using aggressive detergents may damage the surface treatment of these components.

CAUTION

NEVER USE CLOTHS SOAKED IN PETROL, DIESEL OIL OR KEROSENE FOR CLEANING THE PAINTED OR PLASTIC SURFACES SO AS NOT TO DAMAGE THE LUSTRE FINISH OR ALTER THE MECHANICAL PROPERTIES.

CAUTION

DO NOT USE WATER (OR LIQUIDS) AT TEMPERATURES OVER 40°C (104°F) WHEN CLEANING THE VEHICLE PLASTIC PARTS. DO NOT AIM HIGH PRESSURE AIR/WATER JETS OR STEAM JETS DIRECTLY ON THESE COMPONENTS. DO NOT USE ALCOHOL OR SOLVENTS TO CLEAN ANY RUBBER OR PLASTIC SADDLE COMPONENTS USE WATER AND MILD SOAP.

CAUTION

DO NOT USE SOLVENTS OR PETROL BY-PRODUCTS (ACETONE, TRICHLOROETHYLENE, TURPENTINE, PETROL, THINNERS) TO CLEAN THE SADDLE. USE INSTEAD DETERGENTS WITH SURFACE ACTIVE AGENTS NOT EXCEEDING 5% (NEUTRAL SOAP, OR NEUTRAL DETERGENTS).

DRY THE SADDLE WELL AFTER CLEANING.

THE USE OF WAX OR SIMILAR PRODUCTS COMPROMISES THE SAFETY OF THE SADDLE ITSELF.



WHEN USING A SYSTEM OF PRESSURE WASHING (AFTER CHECKING THAT ANY DETERGENTS ARE COMPATIBLE WITH THE MOTORCYCLE FINISH), KEEP A DISTANCE OF AT LEAST ONE METRE.



CLEAN THE VEHICLE IMMEDIATELY WITH COLD WATER AFTER RIDING ON A ROAD TREATED WITH SALT: SALT IS HIGHLY CORROSIVE.

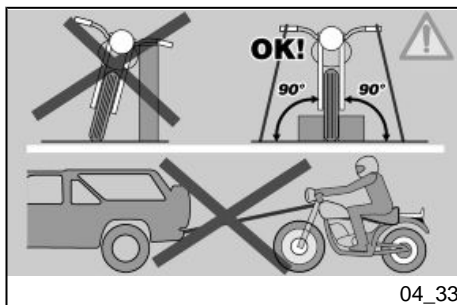

04_33

Transport (04_33)**NOTE**

BEFORE TRANSPORTING THE VEHICLE, CAREFULLY EMPTY THE FUEL TANK AND CHECK THAT IT IS COMPLETELY DRY.

WHILE IT IS BEING MOVED, THE VEHICLE MUST REMAIN IN THE VERTICAL POSITION AND BE FIXED SECURELY IN POSITION IN ORDER TO AVOID SPILLING FUEL OR OIL.

IN CASE OF FAILURE, DO NOT TOW THE VEHICLE BUT CONTACT A ROAD ASSISTANCE SERVICE INSTEAD TO HAVE THE INFLAMMABLE FLUIDS DRAINED .

V100 Mandello - V100 Mandello S



Chap. 05
Technical data

DIMENSIONS AND MASS

Maximum Length	2125 mm (83.66 in)
Maximum width	835 mm (32.87 in)
Height (adjustable at the windshield)	1210 - 1300 mm (47.63 - 51.18 in)
Wheelbase	1475 mm (58.07 in)
Kerb weight	233 kg (513.68 lb)

ENGINE

Type	Four-stroke, 90° transverse V-twin
Number of cylinders	2
Engine capacity	1042 cc (63.59 cu in)
Bore / stroke	96 x 72 mm (3.77 x 2.83 in)
Compression ratio	12.6 ± 0.5 : 1
Ignition	Electric
Idle engine speed	1400 +/- 100 rpm

Clutch	Multi plate wet clutch with anti-judder function.
Lubrication system	pressure-fed, controlled by valves and trochoidal pump
Air filter	cartridge-type dry filter
Cooling	Forced coolant circulation system.

GEARBOX

Type	mechanical, 6 speeds with foot lever on the left hand side of the engine
------	--

CAPACITY

Fuel tank capacity (including reserve)	17 l (3.74 UK gal; 4.49 US gal)
Fuel tank reserve capacity	3.5 +/- 0.5 l (0.77 +/- 0.11 UK gal; 0.92 +/- 0.13 US gal)
Engine oil	Oil change and oil filter replacement: 4900 cc in (299.02 cu in)
Bevel gear set oil	250 cm ³ (15.26 cu in)

Bevel gear oil (in case of replacement)	225 cc (13.73 cu in) MAX
Seats	2
Max. vehicle load	443 kg (976.64 lb) (rider + passenger + luggage)

TRANSMISSION

Primary drive	with gears, ratio: $31/48 = 1 : 1,548$
Gear ratios, 1st gear	$14 / 37 = 1 : 2.642$
Gear ratios, 2nd gear	$17 / 33 = 1 : 1,941$
Gear ratios, 3rd gear	$20 / 31 = 1 : 1,55$
Gear ratios, 4th gear	$22 / 28 = 1 : 1,272$
Gear ratios, 5th gear	$24 / 26 = 1 : 1,083$
Gear ratios, 6th gear	$25 / 24 = 1 : 0,96$
Final drive	with shaft, ratio $12 / 38 = 1 : 3,166$

FUEL SYSTEM

Type	Electronic injection (Marelli 11MP)
Throttle body	Ø 52 mm (2.05 in)

Fuel	Unleaded gasoline E10 (95 R.O.N.)
------	-----------------------------------

CHASSIS

Type	high strength tubular steel frame
Steering rake angle	24.7°
Trail	104 mm (4.095 in)

SUSPENSION

Front (V100 Mandello)	hydraulic telescopic fork, Ø 41 mm (1.61 in)
Rear (V100 Mandello S)	electronically controlled hydraulic telescopic fork, diameter 43 mm (1.69 in)
Travel (V100 Mandello)	130 mm (5.11 in)
Travel (V100 Mandello S)	130 mm (5.11 in)
Rear	Swingarm in die-cast light alloy with 1 shock absorber with adjustable spring pre-loading and hydraulic brake extension.
Travel (V100 Mandello)	130 mm (5.11 in)
Travel (V100 Mandello S)	130 mm (5.11 in)

BRAKES

Front	two 320 mm (12.59 in) diam. stainless steel floating discs, calliper with 4 32 mm (1.26 in) diam. counteracting plungers
Rear	280 mm (11.02 in) stainless steel disc, floating calliper with two 28 mm (1.10 in) diameter pistons

RIMS AND WHEELS

Type	die-cast alloy
Front	3.5" x 17"
Rear	6.00" x 17"

TYRES

Front	120 / 70 ZR17 (58W)
Tyre pressure	2.5 bar (250 kPa) (36.26 PSI)
Rear	190 / 55 ZR17 (75W)
Tyre pressure	2.8 bar (280 Kpa) (40.61 PSI)

SPARK PLUGS

Standard	NGK LMAR8EI-7
Spark plug electrode gap	0.8 mm (0.031 in)
Resistance	7.5 KOhm (MAX)

ELECTRICAL SYSTEM

Battery	12 V - 12 Ah
Fuses	40- 30 - 20 - 15 (3) - 10 (2) - 7.5 (6) - 5 (3) - 3 A
Permanent magnet alternator	12V - 550W

BULBS

High beam/low beam light	LED
Fog lights	LED
Front DRL	LED
Turn signal lights	LED
Rear running light / brake light	LED
Dashboard lighting	LED

INDICATOR LAMPS

Gearbox in neutral	LED
High beam headlight	LED
Cruise control warning light	LED
ABS warning light	LED
MI warning light	LED
Turn indicators	LED
Overspeed threshold / gear shift warning lights	LED
Immobilizer warning light	LED
Fuel reserve	LED
MGCT warning light	LED
General alarm	LED
Daytime running lights warning light	LED
Side stand warning light	LED

V100 Mandello - V100 Mandello S



Chap. 06
Programmed
maintenance



Scheduled maintenance table (06_01)

Proper maintenance is a crucial factor in prolonging the durability of the vehicle and keeping it in perfect working order.

To ensure that maintenance is carried out correctly, the constructor has defined the schedule of checks and services (performed at the owner's expense) summarised in the table given in the following page. It is a good idea to report small performance anomalies right away to an **Authorised Service Centre**, without waiting for the next scheduled service, so they can be repaired immediately.

All scheduled maintenance services must be carried out at the prescribed times, even if the specific mileage has not yet been reached. Services must be performed punctually at the correct intervals to maintain the validity of the warranty. For any additional information concerning Warranty procedures and 'Scheduled Maintenance', please consult the 'Warranty Conditions'.

NOTE

CARRY OUT MAINTENANCE OPERATIONS AT HALF THE INTERVALS SPECIFIED IF THE VEHICLE IS USED IN PARTICULAR RAINY OR DUSTY CONDITIONS, OFF ROAD OR FOR TRACK USE.

SCHEDULED MAINTENANCE TABLE

km x 1,000 (mi x 1,000)	1,5 (0.9)	12 (7.5)	24 (14.9)	36 (22.4)	48 (29.8)	60 (37.3)	72 (44.7)	EVERY 12 MONTHS	EVERY 24 MONTHS
Engine oil filler plug O-ring	I	I	I	I	I	I	I	I	I
Fork plug O-ring					I				
Spark plugs		I	R	I	R	I	R		
Alternator belt		I	R	I	R	I	R		R
Steering bearings and steering play	I	I	I	I	I	I	I	I	I

km x 1,000 (mi x 1,000)	1,5 (0.9)	12 (7.5)	24 (14.9)	36 (22.4)	48 (29.8)	60 (37.3)	72 (44.7)	EVERY 12 MONTHS	EVERY 24 MONTHS
Front wheel bearings		I	I	I	I	I	I	I	I
Diagnosis by tool	I	I	I	I	I	I	I	I	I
Brake discs - Pads wear (4)	I	I	I	I	I	I	I	I	I
Air filter		R	R	R	R	R	R		
Engine oil filter	R	R	R	R	R	R	R	R	R
Vehicle general operation	I	I	I	I	I	I	I	I	I
Valve clearance			I		I		I		
Head cover gasket	I	I	I	I	I	I	I		
Engine oil discharge plug aluminium gasket	R	R	R	R	R	R	R	R	R
Transmission oil discharge plug gasket			R		R		R		
Gasket for the engine oil filter fastening screw	R	R	R	R	R	R	R	R	R
Brake systems	I	I	I	I	I	I	I	I	I
Light circuit	I	I	I	I	I	I	I	I	I
Safety switches	I	I	I	I	I	I	I	I	I
Brake fluid	I	I	I	I	I	I	I	I	R
Clutch fluid	I	I	I	I	I	I	I	I	R
Coolant	I	I	I	I	I	I	I	I	R
Fork oil (5)					R				
Engine oil (3)	R	R	R	R	R	R	R	R	R
Final drive oil			R		R		R		
Headlight aiming		I	I	I	I	I	I		

km x 1,000 (mi x 1,000)	1,5 (0.9)	12 (7.5)	24 (14.9)	36 (22.4)	48 (29.8)	60 (37.3)	72 (44.7)	EVERY 12 MONTHS	EVERY 24 MONTHS
Fork oil seals (1)		I	I	I		I	I		
Tyres - pressure / wear (2)	I	I	I	I	I	I	I	I	I
Transmission oil filler plug washer			R		R		R		
Nut/bolt tightness	I	I	I	I	I	I	I		
Suspensions and stability			I		I		I	I	I
Head cover fastening screws dampers	I	I	I	I	I	I	I		
Filter box drain plug		C	C	C	C	C	C	C	C
Brake lines		I	I	I	I	I	I		
Fuel pipes		I	I	I	I	I	I	I	I

I: Check and clean, adjust, lubricate or replace, if necessary

C: clean

R: replace

A: adjust

(1): Replace in case of leaks

(2): Check every month

(3): Check every 500 km (310 miles)

(4): Check and clean, adjust or replace if necessary every 1000 km (621 miles)

(5): Replace at whichever of the following occurs first: 48,000 km (29,800 mi) or 4 years



06_02

Recommended products (06_02)

Piaggio Group recommends the use of products from its Castrol official partner for the scheduled maintenance of its vehicles.

Only use lubricants and fluids which meet or exceed the performance characteristics specified. This also applies when topping up only.

TABLE OF RECOMMENDED PRODUCTS

Product	Description	Specifications
Engine oil 10W -50	Synthetic-based lubricant for high performance four-stroke engines.	SAE 10W 50; API SL; JASO MA2
75W-140 lubricant for gearboxes and transmissions	Synthetic lubricant for gearboxes and transmissions	SAE 75W-140 - API GL5
Anti-freeze liquid, ready to use, colour red	Glycol ethylene based antifreeze liquid with organic additive technology corrosion inhibitor. Colour red, ready to use.	ASTM D 3306 - ASTM D 4656 - ASTM D 4985 - CUNA NC 956-16
Fork oil 7.5W	Fork oil.	SAE 7.5W
Molybdenum disulphide grease	Lithium grease with molybdenum disulphide.	Grey black grease
Petroleum jelly	neutral grease for battery terminals	-
DOT 4 brake fluid	Synthetic brake fluid.	SAE J 1703; FMVSS 116; ISO 4925; CUNA NC 956 DOT4

TABLE OF CONTENTS

A

Advanced functions: 51
Air filter: 150
Alarms: 28

B

Battery: 12, 154, 156
Brake: 11, 122, 152, 167
Brake fluid: 11
Brake lever: 122
Brake pedal: 122

C

Clutch: 123, 153
Clutch fluid: 153
Clutch lever: 123
coolant: 10, 151
Coolant: 10, 151

D

Disc brake: 167
Display: 22

E

Engine oil: 11, 144, 146
Engine stop: 94

F

Fork: 116, 119
Fuel: 8
Fuses: 157

G

Gearbox oil: 11

H

Headlight: 163
Horn: 88

I

Identification: 102
Immobilizer: 97
Instrument panel: 20

M

Maintenance: 143, 185, 186
Maintenance Table: 186
Mirrors: 165

O

Oil filter: 146

R

rear-view mirrors: 165
Recommended products:
189

S

Saddle: 99
Scheduled maintenance:
186
Shock absorbers: 111, 113
Spark plug: 149
Stand: 133
Start-up: 93
Stop switch: 94

T

Technical data: 177
Turn indicators: 165
Tyres: 147

U

Use: 105

W

Warning lights: 9



THE VALUE OF SERVICE

As a result of continuous updates and specific technical training programmes for Moto Guzzi products, only **Moto Guzzi** Official Network mechanics know this vehicle fully and have the specific tools necessary to carry out maintenance and repair operations correctly.

The reliability of the vehicle also depends on its mechanical conditions. Checking the vehicle before riding it, its regular maintenance and the use of **original Moto Guzzi spare parts** only are essential factors!

For information on the nearest **Official Dealer and/or Service Centre** consult our website:

www.motoguzzi.com

Only by requesting Moto Guzzi original spare parts can you be sure of purchasing products that were developed and tested during the actual vehicle design stage. All Moto Guzzi original spare parts undergo quality control procedures to guarantee reliability and durability.

The descriptions and images in this publication are given for illustrative purposes only and are not binding.

While the basic characteristics as described and illustrated in this booklet remain unchanged, Piaggio & C. S.p.A. reserves the right, at any time and without being required to update this publication beforehand, to make any changes to components, parts or accessories, which it considers necessary to improve the product or which are required for manufacturing or construction reasons.

Not all versions/models shown in this publication are available in all countries. The availability of individual versions should be checked with the Official Moto Guzzi sales network.

The Moto Guzzi brand is owned by Piaggio & C. S.p.A.

© Copyright 2023 - Piaggio & C. S.p.A. All rights reserved. Reproduction of this publication in whole or in part is prohibited.

Piaggio & C. S.p.A. Viale Rinaldo Piaggio, 25 - 56025 PONTEDERA (PI), Italy

www.piaggio.com